

FURUNO

SATELLITE COMPASS



Models:
SC-130
SC-70

High precision and accurate Heading of 0.25°(SC-130) Perfect for Radar, ECDIS, AIS, Doppler Sonar and Autopilot

The SC-70 and SC-130 are the latest satellite compasses, built on FURUNO's commercial-grade technology platform. These satellite compasses prove their value by increasing the accuracy of other instruments, such as Radar, Target Tracking (TT), ECDIS, AIS, Doppler Sonar and Autopilot.

They provide a highly accurate heading signal to these other technologies by utilizing the very latest GNSS (Global Navigation Satellite System). This satellite system is comprised of GPS, Galileo and GLONASS to ensure the highest precision and a continuous coverage.

The SC-70 and SC-130 provide a variety of data, including GPS Positioning, SOG (Speed Over Ground), COG (Course Over Ground), ROT (Rate Of Turn) and 3-axis speed (bow, stern and longitudinal). All of these data assist with critical maneuvers, such as berthing.

These Compasses are maintenance free and are a great asset for any vessel.



Standard High contrast 4.3" Color LCD
(on the screen, the THD mode)
SC-702

SC-130 SC-70 FEATURES

▶ SC-130 features a Tri-sensor antenna that provides a high system accuracy for the heading of the ship

Provides highly accurate heading data for Autopilot, Radar, Target Tracking, AIS, Doppler Sonar, and ECDIS.

- **0.25° (with SC-130)**

Ideal for medium to large ships navigating in crowded ports and making precise maneuvers, such as berthing.

- **0.4° (with SC-70)**

Ideal for small to medium ships requiring highly accurate heading.

▶ Type-approved as THD, GPS and ROTI*, complying with the following requirements

IMO MSC.116(73) • IMO MSC.112(73) • IMO MSC.526(13) • IMO A.694(17)
IMO MSC.97(73) • IMO MSC.191(79) • IMO MSC.302(87) • IEC 60945 Ed.4
IEC 62288 Ed.3 • IEC 61162-1 Ed. 4 • IEC 61162-2 Ed.1 • IEC 61162-450 Ed.1
IEC 61108-1 Ed.2 • ISO 22090-3 Ed.2 • ISO 20672 Ed.1

* requires the RD-50 as a display unit

▶ Utilizes GNSS such as Galileo and GLONASS for high-precision attitude

• Eliminating the problem of not having enough satellites at hand by using multiple types of satellites

▶ Provide precise data for SOG, COG, and L/L

▶ Super short starting time - 90 seconds

• Once the power is on, it takes about 90 seconds to start
(the starting time will slightly differ depending on the equipment location)

▶ 100% free of regular maintenance, no recurring cost, no mechanical parts

▶ Easily integrated into the existing shipboard network via Ethernet

▶ Rapid follow-up rate 45°/s (twice the IMO high speed craft requirement, 20°/s)

▶ Precision Pitch/Roll data in Analog and Digital formats for Vessel Stabilization, SONAR, etc.

▶ Bow and stern speed monitoring for safe berthing

▶ Easy to retrofit by using existing antenna cabling

• For SC-50/55/60/110/120 (The LAN_CNV option kit is necessary)

SATELLITE COMPASS

SC-130 DISPLAY MODES SC-70

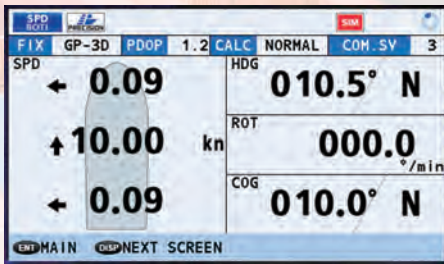

Navigational data screen

- 3-axis speed, as well as the Heading, Rate Of Turn and Course Over Ground can be grasped at a glance. (non-IMO type only)

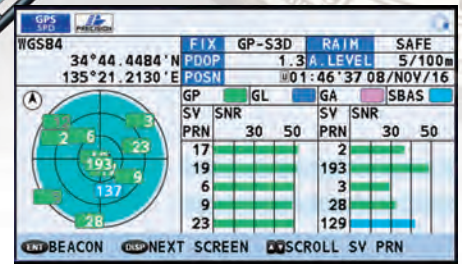

GPS integrity mode

- GPS satellites signal reception including signal strength and signal to noise ratio
- SBAS signal status

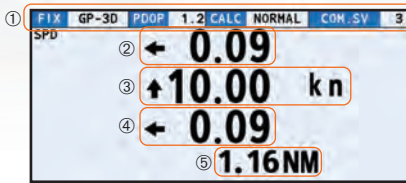

- ① Current selected mode (SDME or THD), integrity status and common satellite number
- ② Transverse speed at bow position
- ③ Longitudinal speed
- ④ Transverse speed at stern position
- ⑤ Distance travelled

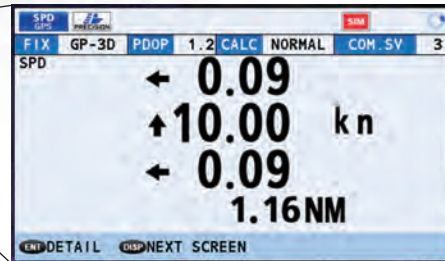

Speed mode

- 3-axis speed of the ship: bow, stern and longitudinal (non-IMO type only)

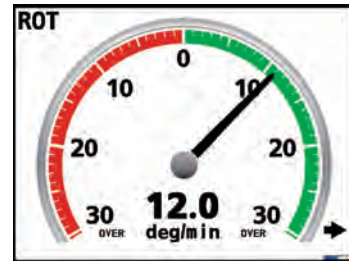

ROTI display mode

- Rate Of Turn Indicator displaying on the RD-50

SC-130 INTERCONNECTION DIAGRAM SC-70

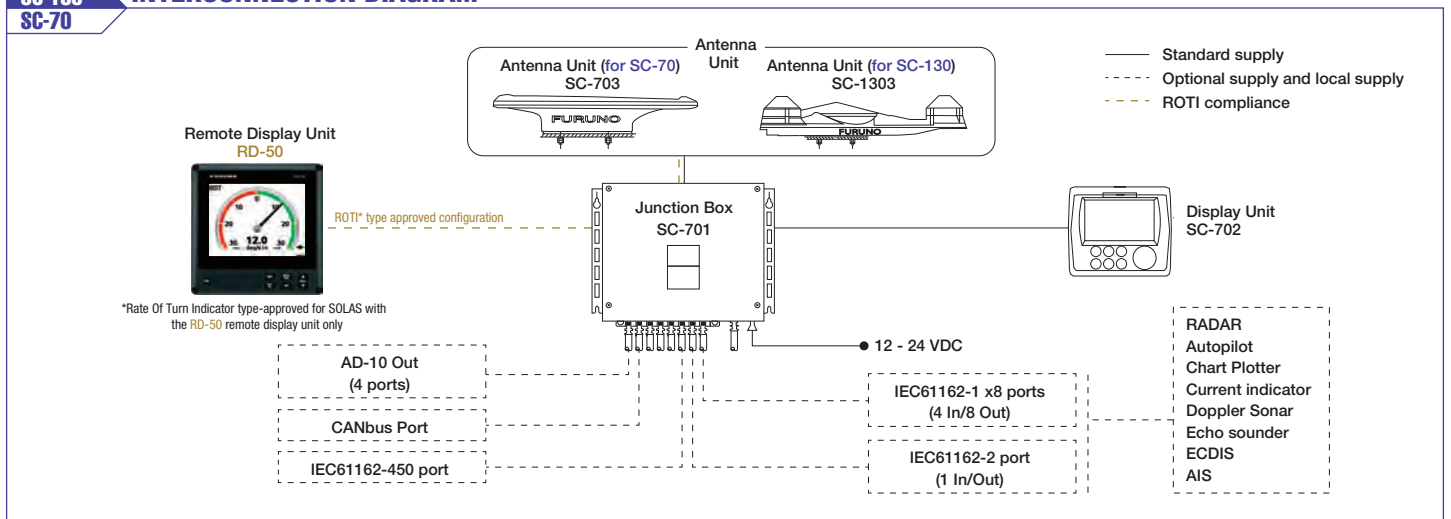

SPECIFICATIONS

GENERAL

Product Name	SATELLITE COMPASS
Receiving frequency	1575.42 MHz (GPS/Galileo), 1602.5625 MHz (GLONASS)
Tracking code	C/A code (GPS), E1B (Galileo), 10F (GLONASS)
Positional accuracy (dependent on ionospheric activity and multipath)	GPS 5 m approx. (2drms, HDOP<4) DGPS 4 m approx. (2drms, HDOP<4) WAAS 3 m approx. (2drms, HDOP<4) MSAS 4 m approx. (2drms, HDOP<4)
Ship's speed accuracy (SOG)	0.02 kn rms (tracking satellites 5 or more)
Ship's speed accuracy (VBW, SOG)	0.2% of ship's speed or 0.02 kn whichever is the greater (tracking satellites 5 or more, at antenna unit)
Course accuracy	SC-70 0.4° rms, SC-130 0.25° rms
Course resolution	0.1°, 0.01°, 0.001° (select from menu)
Tracking bearing	45°/s
Position fixing time	90 s approx. (typical)
Attitude accuracy	Pitch/ Roll: 0.4° rms
Attitude resolution	0.1°, 0.01°, 0.001° (select from menu)
Rate of turn	0.1°, 0.01°, 0.001°/min (select from menu)
Heave accuracy	5 cm (1σ)

DISPLAY UNIT

Screen	4.3-inch color LCD, 95.04 mm (W) x 87.12 mm (H)
Resolution	480 x 272 dots (WQVGA)
Brilliance	600 cd/m² typical
Contrast	17 levels
Display mode	Heading, Nav data, Rate of turn and Speed modes (Non-IMO mode only)
Visible distance	0.65 m nominal

INTERFACE (JUNCTION BOX)

Number of ports (junction box)	
IEC61162-2:	1 port (IN: 1, OUT: 1)
IEC61162-1:	8 ports (IN: 4, OUT: 8)
External beacon input (DATA5 port):	RTCM SC-104 V2.3 (RS-485), ITU-R M823
NMEA2000:	1 port
AD-10:	4 ports, for heading output
RS-485:	1 port, for display unit connection
LAN (IEC61162-450):	2 ports, Ethernet, 100Base-TX, RJ45 connector, IGMPv2 acceptable

Data sentences

Serial data	Input	ACK, ACM, ACN, HBT, HDT*1, MSK, MSS, THS, VBW*2, VDR*2
	Output	ALC, ALF, ALR, ARC, DTM, GBS, GGA, GLL, GNS, GRS, GSA, GST, GSV, HBT, HDG*2, HDM*2, HDT*1, HRM*2, MSK, POS, RMC, ROT, THS, VBW*2, VDR*2, VHW*2, VLW*2, VTG, XDR*2, ZDA
Ethernet data	Input	ACK, ACM, ACN, HBT, SRP
	Output	ALC, ALF, ALR, ARC, DTM, GBS, GGA, GLL, GNS, GRS, GSA, GST, GSV, HBT, HDG*2, HDM*2, HDT*1, HRM*2, POS, RMC, ROT, SRP, THS, VBW*2, VDR*2, VHW*2, VLW*2, VTG, XDR*2, ZDA

Output proprietary sentences		PFEC GPatt, GPive, GPimu, pidat, pireq
PGN	Input	059392/904, 060928, 061184, 126208/720/996
	Output	059392/904, 060928, 061184, 065280, 126208/464/720/992/996, 127250/251/252/257/258, 129025/026/029/033/044/291/539/540/545/547, 130310/312/314/316/577/578/822/823/842/843/845/846

IEC61162-450 transmission group	
Input	MISC, SATD, NAVD, NETA, PROP
Output	Arbitrary (default: SATD)

Other network function excepted IEC61162-450 NTP, HTTP

*1: Not used for SOLAS vessels.

*2: for Non-IMO types only.

POWER SUPPLY

Junction box	12-24 VDC: 2.1-1.1 A (included antenna unit and display unit)
Rectifier (PR-240, option)	100-115/220-230 VAC, 1 phase, 50-60 Hz and 24 VDC

ENVIRONMENTAL CONDITIONS

Ambient temperature	Antenna unit -25°C to +55°C (storage: +70°C) Display unit/ Junction box -15°C to +55°C
Relative humidity	95% or less at +40°C
Degree of protection	Antenna unit IP56 Display unit IP22 (IP35: option) Junction box IP20 (IP22: bulkhead mount)
Vibration	IEC 60945 Ed.4

EQUIPMENT LIST

Standard		Optional supply	
1	Antenna unit	SC-703 x 1	1 AC/DC Power Supply Unit PR-241
		SC-1303 x 1	2 Alarm Monitoring IF-2503/2550
2	Display Unit	SC-702 x 1	3 Interface Unit IF-NMEA SC
3	Junction Box	SC-701 x 1	4 Remote Display RD-50
4	Installation Materials		5 Connector (waterproof) FRU-RJ-PLUG-ASSY
			6 Modular Connector MPSS588-C
			7 LAN_CNV Kit OP20-47/48
			8 Cable Assembly M12-05BFFM-010/020/060
			9 Connector (NMEA) SS-050505-FMF-TS001 x 1
			10 Terminal Resistor (Micro) LTWMC-05BFFT-SL8001 x 1
			LTWMC-05BMMT-SL8001 x 1

Display unit (hanger)

SC-702 0.7 kg, 1.5 lb

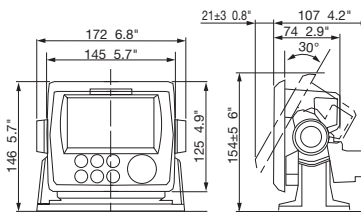

Junction Box

SC-701 2.9 kg, 6.39 lb

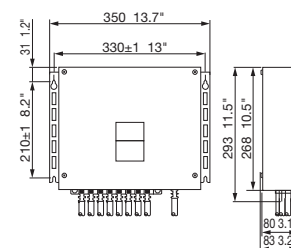

Antenna unit

SC-1303 7.1 kg, 15.6 lb

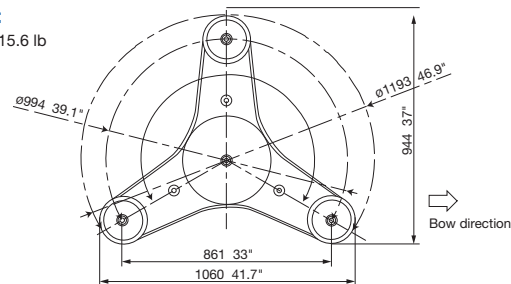

SC-703 2.8 kg, 6.17 lb

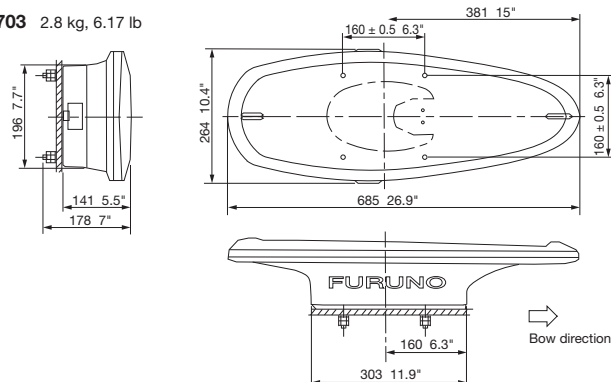

Satellite Compass is a trademark of FURUNO ELECTRIC CO.,LTD

All brand and product names are registered trademarks, trademarks or service marks of their respective holders. SPECIFICATIONS SUBJECT TO CHANGE WITHOUT NOTICE

FURUNO ELECTRIC CO., LTD.

www.furuno.com

Find your local contact point



F-2512LB
Catalogue No. CA00002785