

FURUNO

NAV*pilot*

Model **NAVpilot-10000**

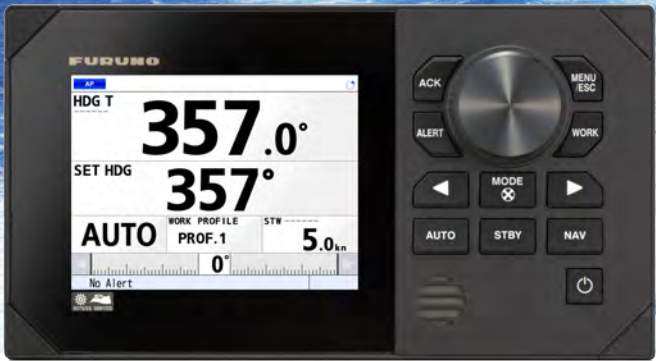

NMEA2000
Certified

www.furuno.com

The logo for NAVpilot, featuring the word "NAV" in a bold, blue, sans-serif font, followed by "pilot" in a smaller, italicized, blue, sans-serif font. The background of the entire page is a photograph of a blue body of water with a city skyline in the distance under a clear sky.

Model NAVpilot-1000

Steering Straight with AUTO Mode

The NAVpilot-1000 takes the helm with an advanced steering algorithm that is designed for larger vessels. Specially designed features, like TURN Mode, ensure that you make smooth turns with confidence.

► Work Profiles

When vessels are operated on a daily basis, sea conditions are different depending on weather or locations. In addition, preference on how-to-steer is also different depending on operators. The NAVpilot-1000 can save a total of six (6) patterns of Work Profiles. Parameters set in Auto Tuning or manual adjustment can be assigned to each profile. Simply select one of the suitable profiles for the day, location or operator.

► Auto Tuning

Before navigating with the NAVpilot-1000, Auto Tuning helps to adjust control parameters. While Auto Tuning, the vessel will run in zig-zag towards the preset heading and automatically adjust rudder gain, counter rudder, and rate of turn to match with vessel characteristics.





NAVpilot-1000 is compatible with a variety of vessel types.

Supported Propulsion Type

- Inboard
- Stern drive
- Water jet
- Azimuth Drive

- * Single rudder and single rudder drive with multi-rudders (single control) are supported.
- * Independently controlled/moved multiple rudder drives are not supported.
- * Outboard, sailboat, azimuth drive (independent control) are not supported.

Supported Steering Interface

- Analog rudder drive (Voltage/Current)
- Solenoid (or relay*)

- * A relay must be used when connecting to a rudder system that uses dry-contact signals.



INTERCONNECTION DIAGRAM

Non-IMO type only

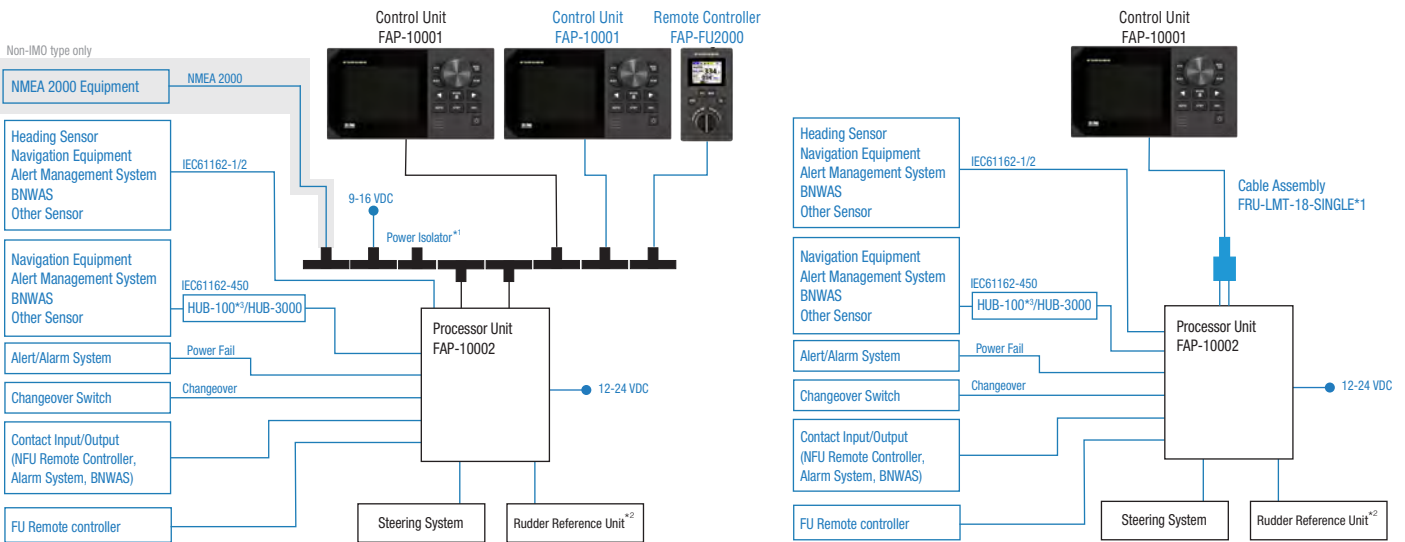

An emergency stop method is required for safety at emergency. Refer to Installation Manual for details.

*1 Power for devices with LEN≤42 is supplied via the processor. For devices exceeding this limit (LEN>42), connect the power isolator to the NMEA 2000 network and provide the external power supply to the backbone. The LEN value of FAP-10001 is 14, and the LEN value of FAP-FU2000 is 3.

*2 FAP-6112 (optional supply) or third-party RRU's.

*3 HUB-100 can only be used for IEC61162-450 Ed.1 compliant network.

An emergency stop method is required for safety at emergency. Refer to Installation Manual for details.

*1 The single cable configuration is for the non IMO type only because this configuration is not listed in the Module B certificate.

*2 FAP-6112 (optional supply) or third-party RRU's.

*3 HUB-100 can only be used for IEC61162-450 Ed.1 compliant network.

- ▶ HCS (Heading Control System) type-approved Autopilot
- ▶ Both IMO and Non-IMO Configurations Available
- ▶ The NAVpilot-1000 covers larger boats from commercial vessels to luxury yachts.
- ▶ Follow-Up type remote controller with IMO Module B type-approved (Option)

HCS Type-Approved

NAVpilot-1000 received the Type Approval certification for the Heading Control System (HCS) and Heading control system for high speed craft. The Type Approval certifies that the product meets specific safety, quality, and reliability standards required for the international marine industry.



Easily Follow Routes with NAV Mode *Non-IMO mode only

The NAVpilot-1000 helps steer vessels on a monitored or activated route with NAV mode.

Interconnect with MFD *Non-IMO mode only

The NAVpilot-1000 can be connected to FURUNO's NavNet TZtouch series MFDs via NMEA 2000. AUTO and NAV modes can be activated from the MFD screen, as well as adjusting the set course while navigating.

*1 TZT10X/13X/16X/22X/24X/BBX: All software versions
 TZT9F/12F/16F/19F: Software version 3.56 or later
 TZT2BB: Software version 9.56 or later

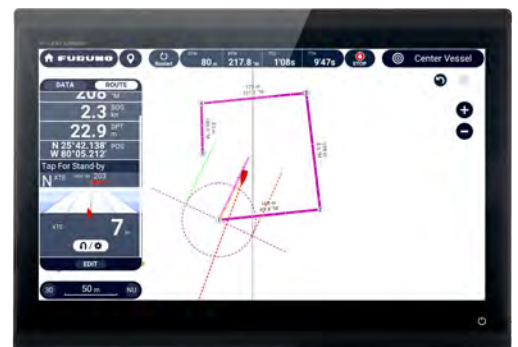

*Photo: NavNet TZtouchXL TZT16X





Easy to Read and Robust Controls

The NAVpilot-1000 comes with a 5.7" color control unit. Large, high-contrast characters are easy to read on the color LCD.

The robust rotary knob and buttons are comfortable to rotate and press even in rough sea conditions.

Remote Controller with IMO Module B type-approved configuration (Option)

The FAP-FU2000 is a Follow-Up type remote controller for the NAVpilot-1000.

It features a robust housing and lever designed to withstand frequent course adjustments and comes standard with two types: a short lever for upper side mounting, and a long lever for lower-side mounting.

By connecting it to the same backbone as the NAVpilot-1000 control unit, the remote controller receives power and enables autopilot operation.

With IPX6 waterproof protection, it is also suitable for outdoor installation on the wings.



Left: Short Lever / Right: Long Lever

The FAP-FU2000 is equipped with a color LCD display. It uses intuitive color coding, red for port, green for starboard, and other colors for alerts and status indicators, making it easy to recognize the current mode, set course, and rudder angle.

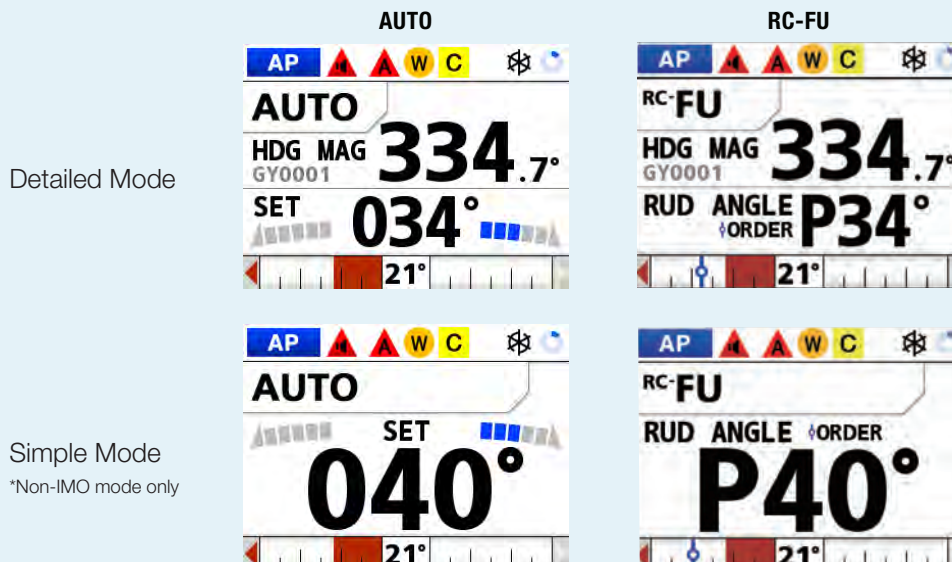

SPECIFICATIONS OF Model NAVpilot - 1000

*The NAVpilot-1000 is designed for use on 100 m or smaller vessels.

CONTROL UNIT

Display	5.7-inch color LCD, 640 x 480 dots (VGA)
Brilliance	720 cd/m ²
Max. number of units in a network	6 units (total of FAP-10001 and FAP-FU2000)
Language	English

PROCESSOR UNIT

Steering mode	STBY, AUTO, Advanced AUTO, NAV*1(Standard/Precision), FU-RC*2, NFU-RC*1 *2, FU-KEY*2, NFU-KEY*2, DISENGAGED (FU/NFU: Follow-Up/Non-Follow-Up, RC/KEY: remote/keyboard control)
---------------	--

*1: Non-IMO mode only, *2: Available only when the RRU is installed.

Rudder gain	Auto / Manual
Counter rudder	Auto / Manual
Trim gain	Auto / Manual
Rate of turn	0.1-10 deg/s
Rudder angle settings	±45 deg
Alert	Heading monitor, Watch, Off heading
Rudder control (analog)	
Voltage	0 to 5 V (min.), -10 to +10 V (max.) (5 mA max.)
Current	4 to 20 mA (load resistance 500 ohm max.)
Solenoid control for rudder on/off	
Isolation	Galvanic/non-galvanic isolation
Connection	Common negative
Load range	3 A max.
Clutch / Bypass drive for rudder	
Isolation	Galvanic/non-galvanic isolation
Connection	Common negative
Load range	3 A max.

REMOTE CONTROLLER (Option)

Display	2.0-inch Color LCD, 320 x 240 dots
Maximum Configuration	5 Units (Maximum of 5 sets of FAP-FU2000 on one network when 1 set of the dedicated control unit FAP-10001 is installed.)
Interface	1 port, NMEA 2000

INTERFACE

Number of ports	
Serial	4 ports, I/O, IEC61162-1 Ed.3 to 5, NMEA 0183 Ver1.5/2.0, 4800/38400 bps
LAN	1 port, Ethernet 100Base-TX, IEEE802.3 data link, IGMPv2 acceptable
NMEA 2000	1 port, for control unit
Universal output	6 ports (dry contact), alarm/status: 100 mA max.
Universal input	4 ports (dry contact)
Power failure	1 port, 12-24 V: 100 mA max.
Changeover switch	1 port (input)
USB	1 port, USB 2.0, for maintenance

POWER SUPPLY

Processor unit	12-24 VDC (10.8-31.2 V): 4.0-2.0 A (control unit: 3 units)
----------------	---

ENVIRONMENTAL CONDITIONS

Ambient temperature	-15 °C to +55 °C (storage: -30 °C to -70 °C)
Relative humidity	93% or less at +40 °C
Waterproofing	Control Unit: IP22 Processor Unit: IP22 Remote Controller: IPX6(Front), IPX5(Rear)

EQUIPMENT LIST

Standard	
Control Unit	FAP-10001
Processor Unit	FAP-10002
Installation Materials	
Spare parts	
Optional Supply	
Control Unit	FAP-10001
Remote Controller	FAP-FU2000
Rudder Reference Unit	FAP-6112
NMEA 2000 Junction Box	FI-5002
Cable Assembly	FRU-NMEA-PFF 1/2/6 m *LAN Cable FRU-NMEA-PMMFF 1/2/6 m FR-FTPC-CY 10/20/30 m FRU-LMT-18-SINGLE 15 m

CONTROL UNIT

FAP-10001

DECK MOUNT
1.2 kg 2.65 lb

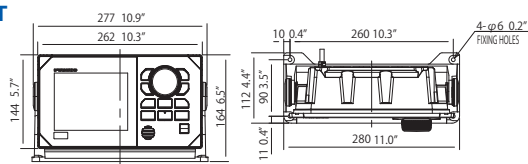

FLUSH MOUNT
0.95 kg 2.09 lb

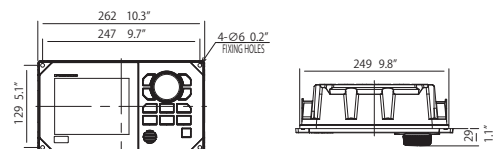

PROCESSOR UNIT

FAP-10002
6.0 kg 13.22 lb

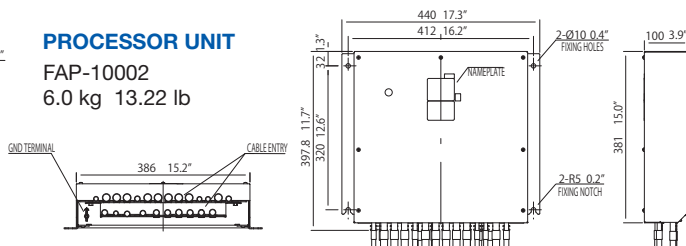

REMOTE CONTROLLER (Option)

FAP-FU2000
0.77 kg 1.70 lb

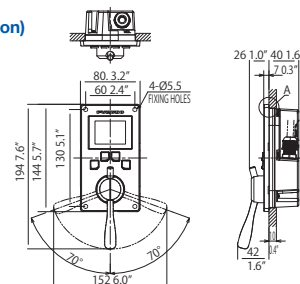

Beware of similar products

All brand and product names are registered trademarks, trademarks or service marks of their respective holders.

SPECIFICATIONS SUBJECT TO CHANGE WITHOUT NOTICE

FURUNO ELECTRIC CO., LTD.

www.furuno.com

Find your local contact point



C-2601LB
Catalogue No. CA000002812