

FURUNO

OPERATOR'S MANUAL

GNSS NAVIGATOR

Model **GP-170**

Link For Operator's Guide

The Operator's Guide for this equipment can be viewed on our official website. You can also download it from the Quick Response Code on the right, or the URL below.



<https://www.furuno.com/en/support/manuals/?pc=chartplotter>

FURUNO ELECTRIC CO., LTD.

9-52 Ashihara-cho,
Nishinomiya, 662-8580, JAPAN

• FURUNO Authorized Distributor/Dealer

All rights reserved. Printed in Japan

Pub. No. OME-44820-P

(MIKU) GP-170

A : JUN. 2014

P : DEC. 04, 2025



0 0 0 1 0 1 0 5 7 2 0

IMPORTANT NOTICE

General

- This manual has been authored with simplified grammar, to meet the needs of international users.
- The operator of this equipment must read and follow the instructions in this manual. Wrong operation or maintenance can void the warranty or cause injury.
- Do not copy any part of this manual without written permission from FURUNO.
- If this manual is lost or worn, contact your dealer about replacement.
- The contents of this manual and the equipment specifications can change without notice.
- The example screens (or illustrations) shown in this manual can be different from the screens you see on your display. The screens you see depend on your system configuration and equipment settings.
- Save this manual for future reference.
- Any modification of the equipment (including software) by persons not authorized by FURUNO will void the warranty.
- The following concern acts as our importer in Europe, as defined in DECISION No 768/2008/EC.
 - Name: FURUNO EUROPE B.V.
 - Address: Rotterdamseweg 30A, 2921 AP, Krimpen aan den IJssel, The Netherlands
- The following concern acts as our importer in UK, as defined in SI 2016/1025 as amended SI 2019/470.
 - Name: FURUNO (UK) LTD.
 - Address: West Building Penner Road Havant Hampshire PO9 1QY, U.K.
- All brand, product names, trademarks, registered trademarks, and service marks belong to their respective holders.

How to dispose of this product

Dispose of this product according to local regulations for the disposal of industrial waste. For disposal in the USA, see the homepage of the Electronics Industries Alliance (<http://www.eiae.org/>) for the correct method of disposal.

How to dispose of a used battery

Some FURUNO products have a battery(ies). To see if your product has a battery, see the chapter on Maintenance. To dispose of a used battery, tape the + and - terminals of the battery before disposal to prevent fire, heat generation caused by short circuit.

In the European Union

The crossed-out trash can symbol indicates that all types of batteries must not be discarded in standard trash, or at a trash site. Take the used batteries to a battery collection site according to your national legislation and the Batteries Directive 2006/66/EU.

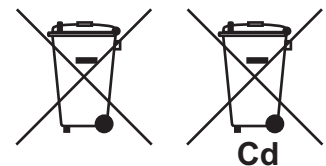

In the USA

The Mobius loop symbol (three chasing arrows) indicates that Ni-Cd and lead-acid rechargeable batteries must be recycled. Take the used batteries to a battery collection site according to local laws.

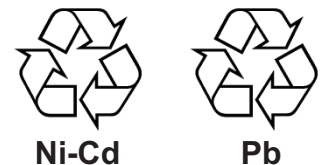

In the other countries

There are no international standards for the battery recycle symbol. The number of symbols can increase when the other countries make their own recycle symbols in the future.



SAFETY INSTRUCTIONS



WARNING

Indicates a condition that can cause death or serious injury if not avoided.



CAUTION

Indicates a condition that can cause minor or moderate injury if not avoided.



Warning, Caution



Prohibitive Action



Mandatory Action



WARNING



Do not disassemble or modify the equipment.

Fire, electrical shock or serious injury can occur.



Turn off the power immediately if water leaks into the equipment or smoke or fire is coming from the equipment.

Failure to turn off the equipment can cause fire or electrical shock. Contact a FURUNO agent for service.



Use the correct fuse.

A wrong fuse can cause fire or serious damage to the equipment.



CAUTION



Do not connect/disconnect the signal cable while turning the power on.

The unit may be damaged.



No single navigation aid (including this unit) should ever be relied upon as the exclusive means for navigating your vessel.

The navigator is responsible for checking all aids available to confirm his position. Electronic aids are intended to assist, not replace, the navigator.

About the TFT LCD

The TFT LCD is constructed using the latest LCD techniques, and displays 99.99% of its pixels. The remaining 0.01% of the pixels may drop out or blink, however this is not an indication of malfunction.

Caution Label(s)

Caution label(s) is(are) attached to the equipment. Do not remove the label(s). If a label is missing or damaged, contact a FURUNO agent or dealer about replacement.

Do not remove cover.
No user-serviceable parts inside.

サービスマン以外の方はカバーを開けないで下さい。

请不要打开盖子。
内部无用户可以维修的器件。

Name: Caution Label
Type: 20-035-1003-0

TABLE OF CONTENTS

FOREWORD	vii
SYSTEM CONFIGURATIONS	ix
1. OPERATIONAL OVERVIEW	1-1
1.1 Controls	1-1
1.2 How to Turn the Power On/Off	1-3
1.3 How to Adjust the Brilliance of the Display and Panel.....	1-4
1.4 How to Select the Display Mode.....	1-5
1.5 Main Menu Overview.....	1-8
1.6 List Overview	1-9
1.7 Context Menu Overview	1-10
2. PLOTTER DISPLAY OVERVIEW, TRACK	2-1
2.1 How to Set the Display	2-1
2.1.1 How to select the background color	2-1
2.1.2 How to zoom in or out the display	2-1
2.1.3 How to change the display orientation	2-1
2.1.4 How to turn the cursor on/off, change cursor size	2-2
2.1.5 How to move the cursor	2-2
2.1.6 How to shift the display	2-2
2.1.7 How to center the cursor position or ship's position	2-3
2.1.8 How to show or hide the grid and change its color.....	2-3
2.1.9 How to show or hide the XTL line and change its color	2-3
2.1.10 How to show or hide the heading line and change its color	2-4
2.1.11 How to set the COG vector	2-4
2.1.12 How to display the time mark	2-5
2.1.13 How to display the names for marks and waypoints	2-5
2.1.14 How to show or hide the weather data	2-5
2.2 Bearing Reference.....	2-6
2.2.1 How to select bearing reference.....	2-6
2.2.2 How to set the magnetic variation	2-6
2.3 About Tracks	2-7
2.3.1 How to start or stop plotting and recording of the track.....	2-7
2.3.2 How to set the track plotting interval	2-7
2.3.3 How to set the track color.....	2-8
2.3.4 How to erase the track	2-8
3. MARKS	3-1
3.1 How to Enter a Mark on the Plotter Display.....	3-1
3.1.1 How to preset mark appearance	3-1
3.1.2 How to enter a mark at the cursor position.....	3-2
3.1.3 How to enter a mark from the mark list	3-2
3.2 How to Enter an Event Mark.....	3-5
3.2.1 How to preset event mark appearance	3-5
3.2.2 How to enter an event mark at own ship's position	3-5
3.2.3 How to enter an event mark from the mark list.....	3-5
3.3 How to Enter a MOB Mark.....	3-6
3.4 How to Edit a Mark or an Event Mark.....	3-7
3.5 How to Erase Marks	3-8
4. ROUTES	4-1
4.1 How to Create a Route	4-1

TABLE OF CONTENTS

4.1.1	How to preset the settings for routes	4-1
4.1.2	How to create a new route with the cursor and the ROUTE key.....	4-3
4.1.3	How to create a new route from the route list	4-4
4.2	How to Edit a Route	4-6
4.2.1	How to change the route name or color	4-6
4.2.2	How to edit a waypoint in a route	4-7
4.2.3	How to temporarily deselect a waypoint in a route.....	4-8
4.2.4	How to delete a waypoint from a route.....	4-9
4.2.5	How to insert a waypoint in a route	4-10
4.2.6	How to change the route direction	4-11
4.2.7	How to copy the route	4-11
4.3	How to Erase a Route	4-12
5.	DESTINATION	5-1
5.1	How to Set a Destination.....	5-1
5.1.1	How to set a cursor position as a destination.....	5-1
5.1.2	How to set a waypoint as a destination.....	5-1
5.1.3	How to set a registered mark as a destination	5-2
5.1.4	How to set a registered route as a destination.....	5-3
5.2	How to Cancel a Destination.....	5-3
5.2.1	How to cancel a destination with the GO TO key.....	5-3
5.2.2	How to cancel a destination from the main menu	5-3
5.2.3	How to cancel a destination from the context menu	5-4
5.3	How to Calculate the Distance, Bearing and TTG (Time To Go) Between Two Points	5-4
5.4	How to Display the ETA and TTG	5-5
5.5	How to Calculate the Trip Distance.....	5-6
5.6	How to Set the Drift.....	5-6
6.	NOTICES.....	6-1
6.1	Audio Notice Type.....	6-1
6.2	Arrival/Anchor Notice	6-2
6.2.1	Arrival notice	6-2
6.2.2	Anchor notice	6-2
6.3	XTE Notice	6-3
6.4	Ship Speed Notice	6-3
6.5	Trip Notice.....	6-4
6.6	DC Report (Satellite Report for Disaster and Crisis Management).....	6-5
6.6.1	DC report log.....	6-5
6.6.2	How to clear the DC report log.....	6-6
6.6.3	How to set the DC report.....	6-6
6.6.4	Popup view.....	6-8
6.6.5	How to set the talker for DC report.....	6-8
7.	DISPLAYS.....	7-1
7.1	Sat view Display.....	7-1
7.2	Highway Display.....	7-4
7.3	Course Display.....	7-5
7.4	Data Display.....	7-6
7.5	LORAN Settings.....	7-9
7.5.1	How to display LORAN on the data screen.....	7-9
7.5.2	How to adjust LORAN station settings.....	7-9
8.	ALERTS	8-1
8.1	Overview	8-1
8.2	Alert List	8-5

8.3	Alert Log	8-5
8.4	How to Acknowledge Alerts.....	8-6
8.5	How to Silence Alerts	8-6
8.6	Responsibility Transfer Alert.....	8-6
8.7	Alert Continuation	8-7
8.8	UTC De-synchronization and Alert Output	8-7
9.	OTHER FUNCTIONS	9-1
9.1	Unit Setup Menu	9-1
9.2	Correction, Offset Menu	9-1
9.3	GNSS Menu	9-4
9.3.1	How to select the positioning system	9-4
9.3.2	How to set the time for smoothing of position, speed and speed average	9-5
9.3.3	How to set the positioning condition	9-5
9.3.4	How to select the RAIM function	9-7
9.3.5	How to select the datum	9-7
9.3.6	How to set the initial position	9-8
9.3.7	How to set the positioning cycle	9-8
9.3.8	How to turn the anti-multipath mode on/off	9-9
9.4	Beacon/SBAS Menu	9-10
9.4.1	How to select the differential corrections to use	9-10
9.4.2	How to set SBAS and beacon	9-11
9.4.3	How to open the station data	9-12
9.4.4	How to set QZSS	9-13
9.5	Language	9-14
9.6	I/O Menu	9-15
9.6.1	How to set the output 1, 2, 3 or 4	9-15
9.6.2	How to set the Ethernet	9-16
9.6.3	How to select the input data	9-18
9.6.4	Line monitor log	9-19
9.6.5	How to set the number of digits displayed for distance and speed	9-20
9.7	How to Set Dual Configuration	9-21
9.8	How to Set ECDIS Sync Configuration	9-22
9.9	User Password Settings	9-23
9.10	How to Set the Demo Mode	9-25
10.	MAINTENANCE	10-1
10.1	Maintenance	10-1
10.2	Fuse Replacement	10-2
10.3	Troubleshooting	10-2
10.4	Equipment Information	10-3
10.5	Self Test	10-4
10.6	Audit Log	10-6
10.7	Backup	10-7
10.8	How to Clear the Memory	10-8
10.9	Checking the Operation of Security Functions	10-9
10.9.1	Regular security inspections	10-9
10.9.2	Security checks during installation	10-10
10.10	Remedy for Cyber Incidents	10-10
10.10.1	Network disturbance	10-10
10.10.2	Password leak	10-10
10.10.3	Data corruption	10-11
APPX. 1	MENU TREE	AP-1
APPX. 2	LIST OF TERMS/ICONS/ SYMBOLS	AP-6

TABLE OF CONTENTS

APPX. 3 TIME DIFFERENCES	AP-9
APPX. 4 GEODETIC CHART LIST	AP-10
APPX. 5 WHAT IS SBAS/ QZSS (SLAS)/DC Report?	AP-11
APPX. 6 PARTS LIST/LOCATION.....	AP-15
APPX. 7 ALERT LIST.....	AP-16
SPECIFICATIONS	SP-1
INDEX.....	IN-1

FOREWORD

A Word to the Owner of the GP-170

Congratulations on your choice of the FURUNO GP-170 GNSS Navigator. We are confident you will see why the FURUNO name has become synonymous with quality and reliability.

Since 1948, FURUNO Electric Company has enjoyed an enviable reputation for innovative and dependable marine electronics equipment. This dedication to excellence is furthered by our extensive global network of agents and dealers.

Your equipment is designed and constructed to meet the rigorous demands of the marine environment. However, no machine can perform its intended function unless properly installed and maintained. Please carefully read and follow the operation and maintenance procedures set forth in this manual.

We would appreciate feedback from you, the end-user, about where we are achieving our purposes.

Thank you for considering and purchasing FURUNO equipment.

Features

The main features of the GP-170 are as shown below.

- High-resolution color LCD
- Comprehensive navigation data displays
- A DGPS/DGLONASS beacon receiver (internal or external) can be connected to the GP-170 to add DGPS/DGLONASS capability.
- Storage for 1,000 waypoints, 100 routes (99 for creating, one for external input), 1,000 tracks and 2,000 marks
- External USB flash memory capability
- Notices: Arrival/Anchor, XTE (Cross-track Error), Ship speed, Trip, DC report (Satellite Report for Disaster and Crisis Management)
- Alerts: Warning, Caution
- Man overboard feature records position at time of man overboard and provides continuous updates of range and bearing when navigating to the MOB position.
- Unique Highway display provides a graphic presentation of ship's progress toward a waypoint.
- User-programmable nav data displays provide digital navigation data.
- Two dual differential GPS/GLONASS navigator systems are available.
- Ethernet port for connection to a LAN

Program No.

MAIN: 2051542-03.XX, GPS: 48504650XX,

BEACON: 2051544-01.XX (Requires internal DGPS/DGLONASS beacon receiver.)

XX: Minor change

Open Source Acknowledgement

This product makes use of the following open source software:

b64: Base-64 Encoding Library (<http://synesis.com.au/software/b64.html>)

Portions of this software are copyright © 2012 Synesis Software Pty Ltd. All rights reserved.

CE/UKCA declaration

With regards to CE/UKCA declarations, please refer to our website (www.furuno.com) for further information about RoHS conformity declarations.

Disclosure of Information about China RoHS

With regards to China RoHS information for our products, please refer to our website (www.furuno.com).

SYSTEM CONFIGURATIONS

Basic configuration is shown with solid line.

Single configuration

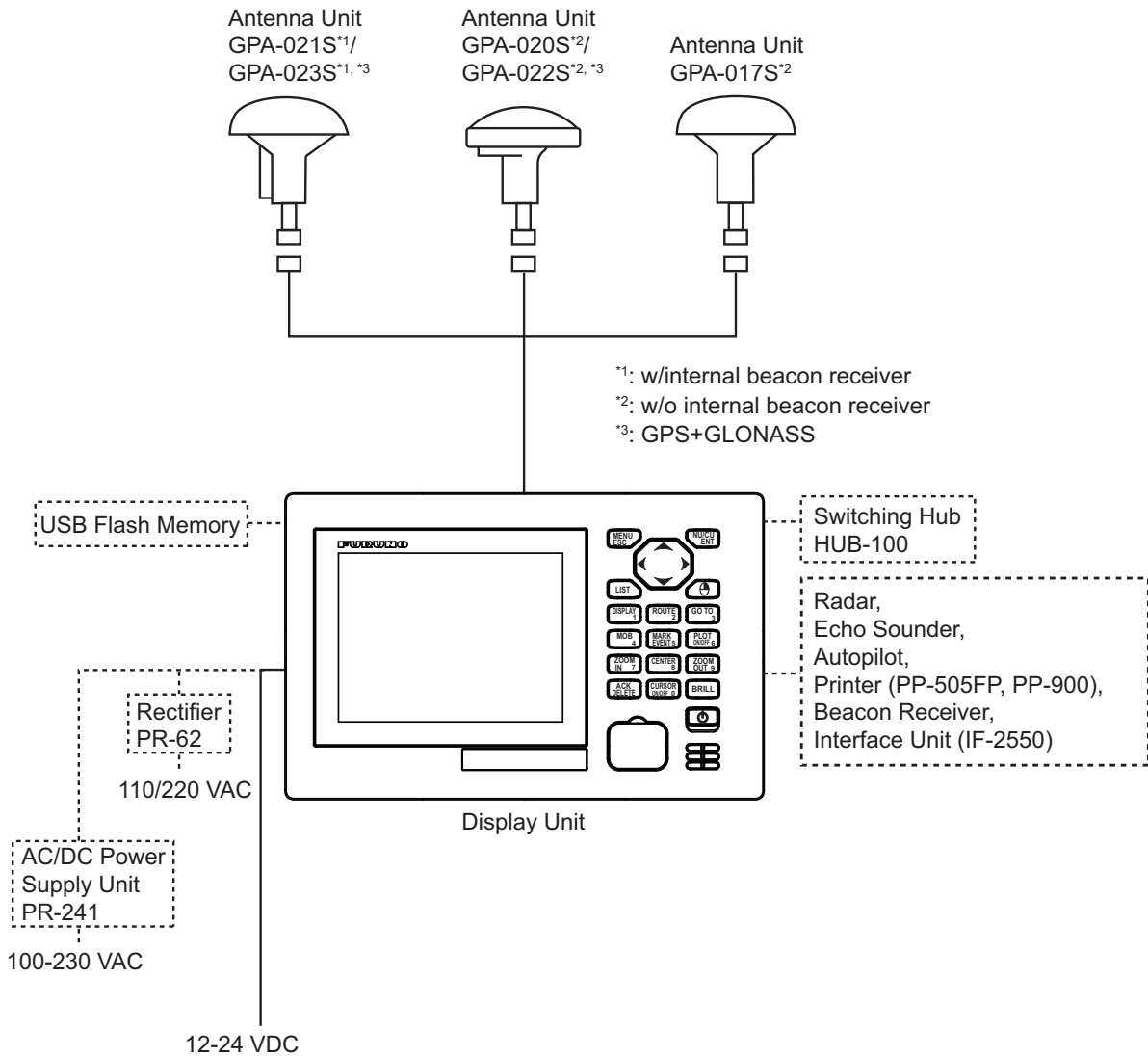

SYSTEM CONFIGURATIONS

Dual configuration (No interface unit used)

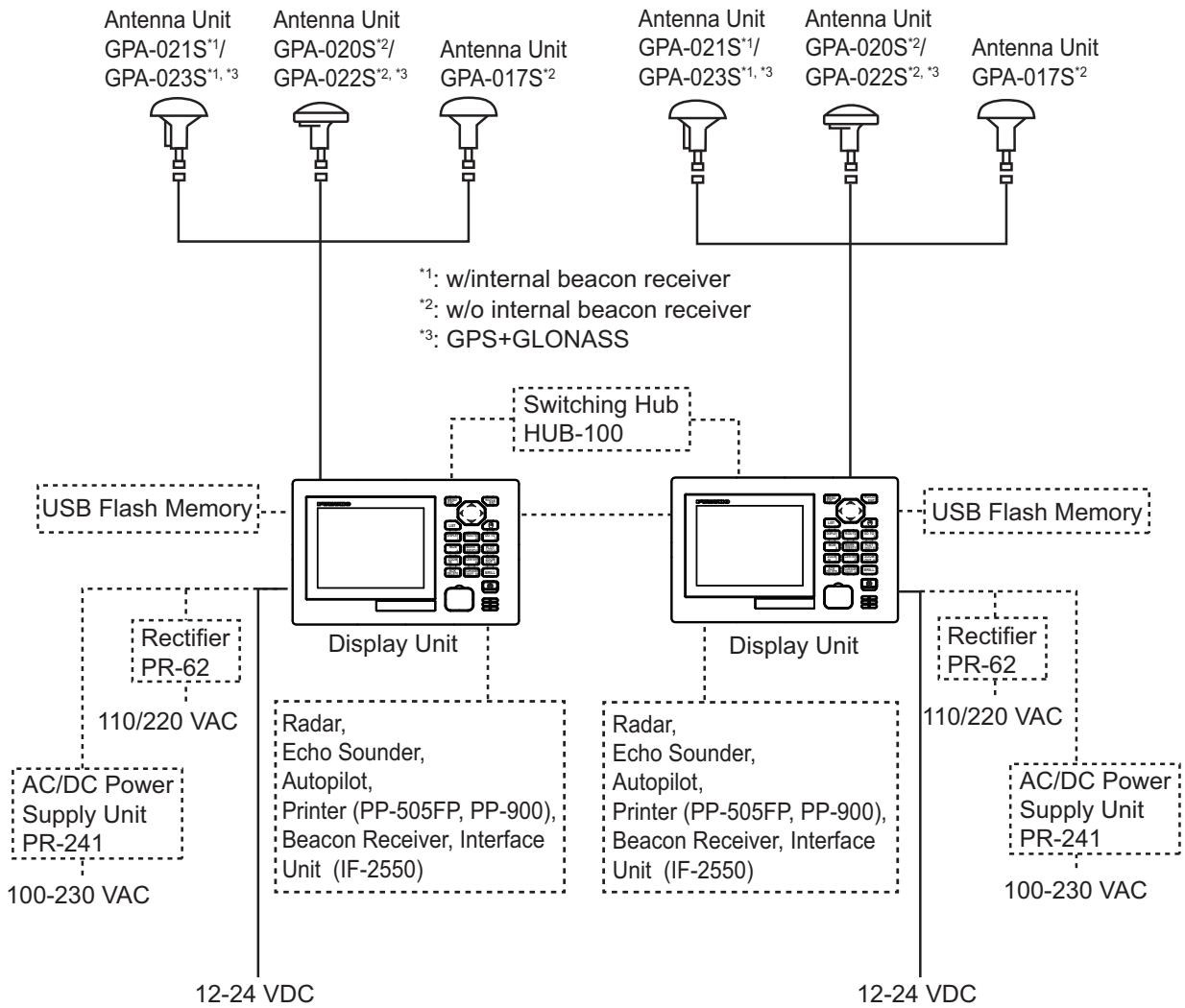

Dual configuration (With IF-2550)

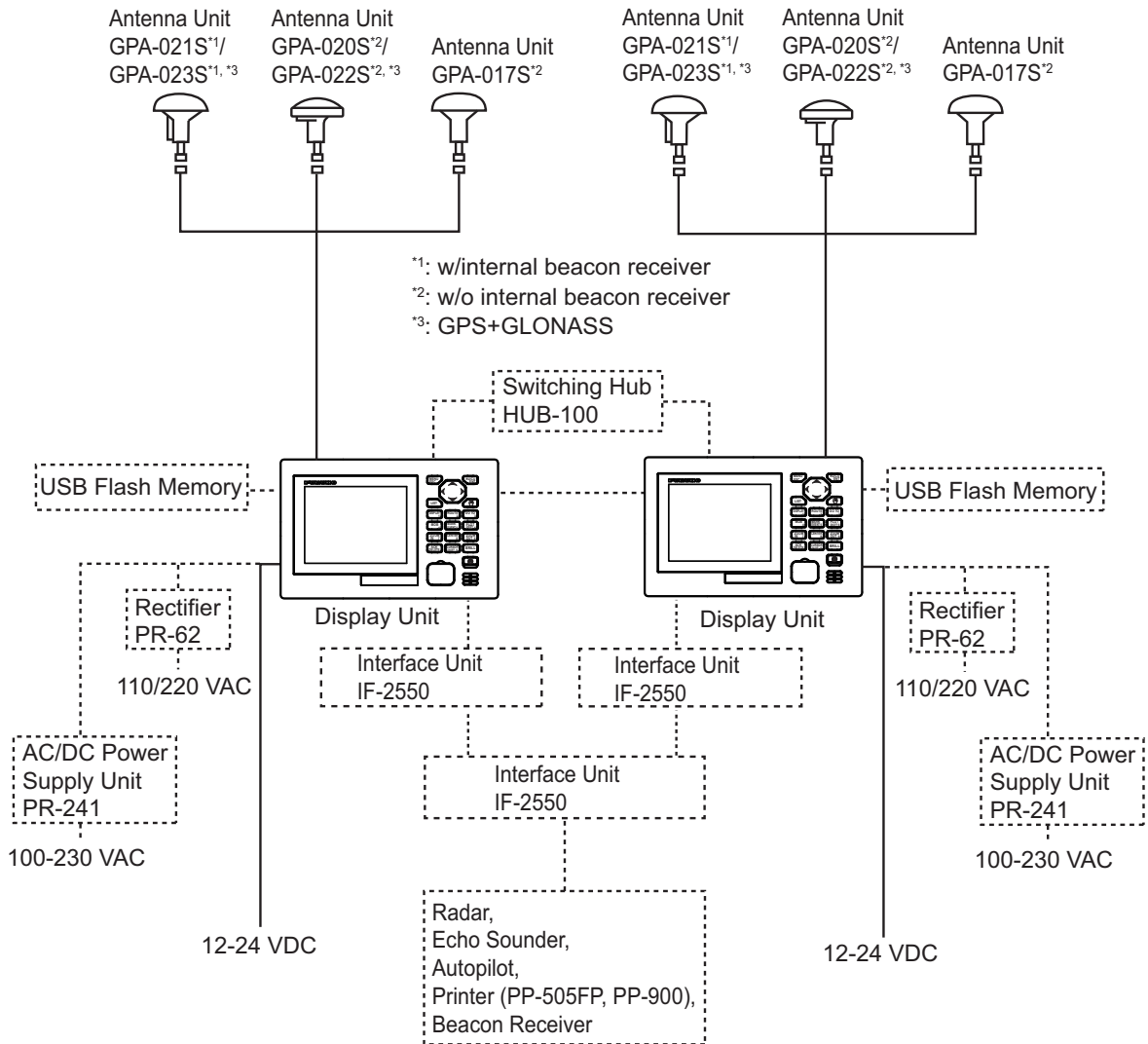

Environmental category

Units	Category
Antenna Unit	Exposed to the weather
Display Unit	Protected from the weather

This page is intentionally left blank.

1. OPERATIONAL OVERVIEW

1.1 Controls

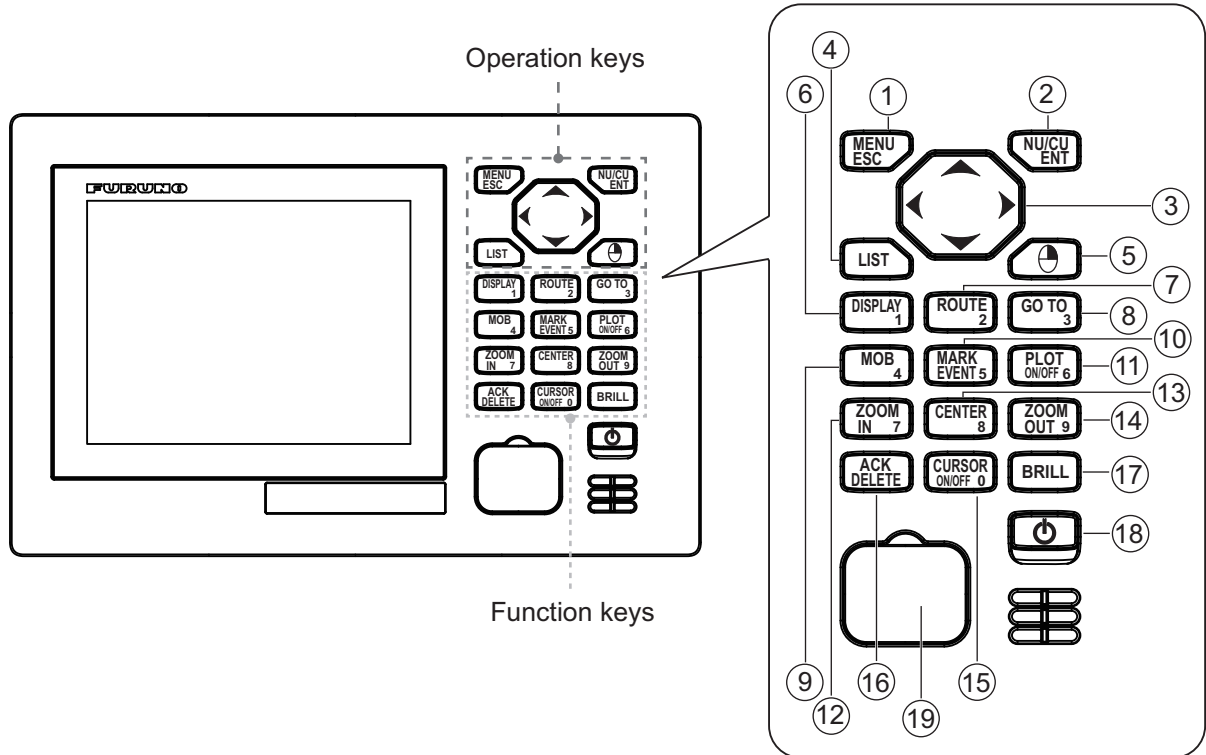

The keys are arranged according to the function.

No.	Control	Function	
		Menu screen	Display mode
1	MENU/ESC	<ul style="list-style-type: none"> Short press: Closes the menu. Long press: Opens the alert list. 	<ul style="list-style-type: none"> Short press: Opens the menu. Short press: Quits current operation. Long press: Opens the alert list.
2	NU/CU ENT	Confirms a selection.	<ul style="list-style-type: none"> Switches the orientation mode between north-up and course-up on the plotter display. Confirms a selection then closes the setting window.
3	Cursorpad	<ul style="list-style-type: none"> ▲ or ▼: Selects the menu item. ◀: Goes back one layer in multi-layer menu. ▶: Goes forward one layer in multi-layer menu. 	<ul style="list-style-type: none"> Shifts display or cursor on the plotter display. Switches display on the sat view (integrity) display.
4	LIST	<ul style="list-style-type: none"> Opens the list. Switches the list (any display → mark list → route list → station list (requires internal DGPS/DGLONASS beacon receiver) → any display). Long-press to switch the list in reverse order. 	
5	Ⓜ (Right-click)	—	Opens the context menu on the plotter display.

1. OPERATIONAL OVERVIEW

No.	Control	Function		
		Menu screen	Display mode	
6	DISPLAY/1	<ul style="list-style-type: none"> • Selects and confirms the selected menu item. • Enters a numeric character. 	Selects the display mode.	
7	ROUTE/2		Starts/stops the registration of a route on the plotter display.	
8	GO TO/3		<ul style="list-style-type: none"> • Sets a destination at the cursor position on the plotter display with cursor on. • Opens the context menu for Go To on the plotter display with cursor off. 	
9	MOB/4		Marks a man overboard position and sets a destination on the plotter display.	
10	MARK EVENT/5		<ul style="list-style-type: none"> • Puts a mark at the cursor position on the plotter display with cursor on. • Puts an event mark at own ship's position on the plotter display with cursor off. 	
11	PLOT ON/OFF/6		Resumes/stops track plotting on the plotter display.	
12	ZOOM IN/7		Zooms in the plotter display.	
13	CENTER/8		<ul style="list-style-type: none"> • Centers the cursor position on the plotter display with cursor on. • Centers own ship's position on the plotter display with cursor off. 	
14	ZOOM OUT/9		Zooms out the plotter display.	
15	CURSOR ON/OFF/0		Turns the cursor on or off on the plotter display.	
16	ACK/DELETE		<ul style="list-style-type: none"> • Acknowledges an unacknowledged alert when the pop-up appears. • Deletes all setting values on the setting window when there is no unacknowledged alerts. 	<ul style="list-style-type: none"> • Acknowledges an unacknowledged alert when the pop-up appears. • Deletes registered data (marks, etc.) at the cursor-selected position on the plotter display when there are no unacknowledged alerts.
17	BRILL		Opens the brilliance adjustment window. Adjusts the display brilliance when the adjustment window opens.	
18	 (Power)		Turns the power on or off.	
19	USB port		For connection of USB flash memory.	

Key sound

When you operate a key, a single beep sounds. If you do not need the key beep, deactivate the beep sound as follows (see section 1.5):

1. Press the **MENU/ESC** key to open the main menu.
2. Select [4 Notice Setting] then [9 Sound].
3. Select [2 Key Sound].
4. Select [2 Off].
5. Press the **MENU/ESC** key to close the main menu.

1.2 How to Turn the Power On/Off

Press the  key to turn the power on. The start-up screen appears for 30 seconds then the last-used screen appears.



Appears when internal DGPS/DGLONASS beacon receiver is installed.

Start-up screen

XX: Program version numbers

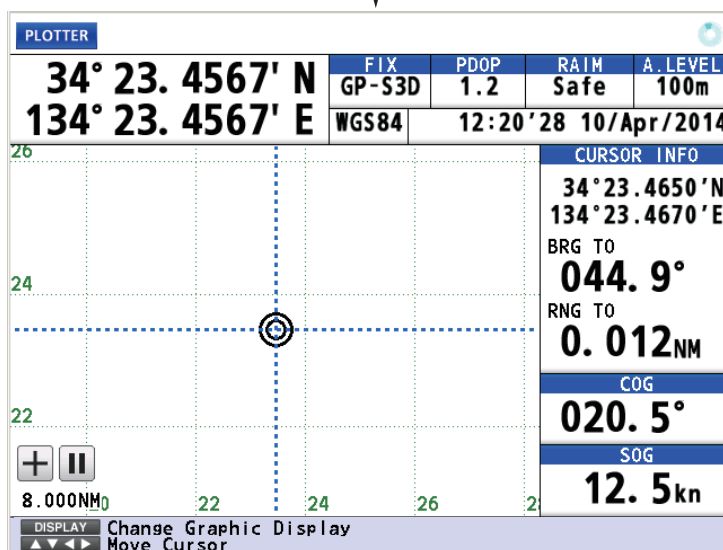

Last-used screen (example: plotter display)

DGPS/DGLONASS beacon receiver

The GP-170 is available in two specifications, with DGPS/DGLONASS beacon receiver and no DGPS/DGLONASS beacon receiver. Only the beacon receiver equipped GP-170 has DGPS/DGLONASS capability. To get DGPS/DGLONASS capability, install the optional internal DGPS/DGLONASS beacon receiver (name: beacon receiver set, type: OP20-42/OP20-55) or connect an external beacon receiver.

Status indications

Indication		System
2D positioning	3D positioning	
GP-2D	GP-3D	GPS
GP-S2D	GP-S3D	GPS + SBAS
GP-D2D	GP-D3D	GPS + Differential

Indication		System
2D positioning	3D positioning	
GP-D2D (Yellow)	GP-D3D (Yellow)	GPS + Differential (WER>10%)
GP-D2D! (Yellow)	GP-D3D! (Yellow)	GPS + Differential (Unmonitored)
GP-Q2D	GP-Q3D	GPS + QZSS
GL-2D	GL-3D	GLONASS
GL-D2D	GL-D3D	GLONASS + Differential
GL-D2D (Yellow)	GL-D3D (Yellow)	GLONASS + Differential (WER>10%)
GL-D2D! (Yellow)	GL-D3D! (Yellow)	GLONASS + Differential (Unmonitored)
GN-2D	GN-3D	Multi
No Fix		No fixed

2D positioning: Three satellites are used.

3D positioning: More than four satellites are used.

Unmonitored: The status of the receiving beacon station is unmonitored.

WER>10%: Word error rate of the receiving beacon station exceeds 10%.

Note: The screen refreshes slower in low ambient temperature.

To turn the power off, press the  key.



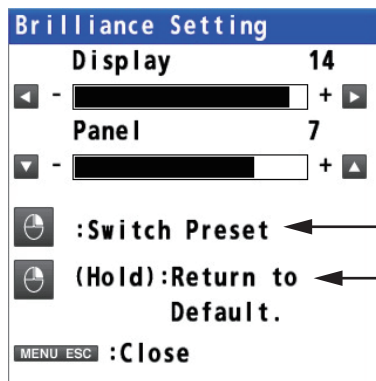

1.3 How to Adjust the Brilliance of the Display and Panel

1. Press the **BRILL** key to show the following setting window.



Switch the color mode between day mode and night mode.

Long-press to restore the settings to default of day mode.

2. To adjust the display brilliance, use the cursorpad ( or ) or the **BRILL** key (setting range: 0 to 15, default: 14 for day mode/6 for night mode).
3. To adjust the panel brilliance, use the cursorpad ( or ) (setting range: 0 to 9, default: 7 for day and night modes).
4. Press the **MENU/ESC** key to close the setting window.

Note 1: The default settings for night mode is 6 for [Display] and 7 for [Panel]. If the display is difficult to see when switching to the night mode, use the cursorpad () to increase the display brilliance.

Note 2: Whenever the brilliance mode is changed, the last-used brilliance for the selected mode is set.

Note 3: When the brilliance is preset, the background color is also preset (see subsection 2.1.1). So both the brilliance and the background color are restored to the default when long-pressing the  key.

1.4 How to Select the Display Mode

There are five display modes: PLOTTER, SAT VIEW (integrity), HIGHWAY, COURSE and DATA. Press the **DISPLAY** key to select the display mode, in the following sequence. To reverse the order, long-press the **DISPLAY** key.

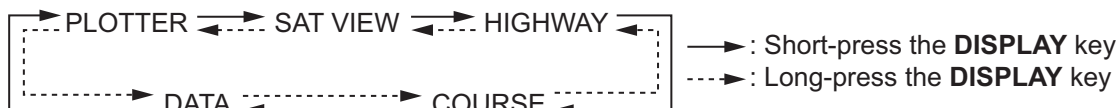

You can turn off the highway, course or data display if its use is not required.

1. Press the **MENU/ESC** key to open the main menu.
2. Select [1 Display] then [9 Display Select].
3. Select [3 Highway], [4 Course] or [5 Data].
4. Select [1 On] or [2 Off]. The display modes which are set to off are skipped when operating the **DISPLAY** key.

Note: The plotter and sat view displays can not be disabled.

5. Press the **MENU/ESC** key to close the main menu.

The data is arranged according to data type.

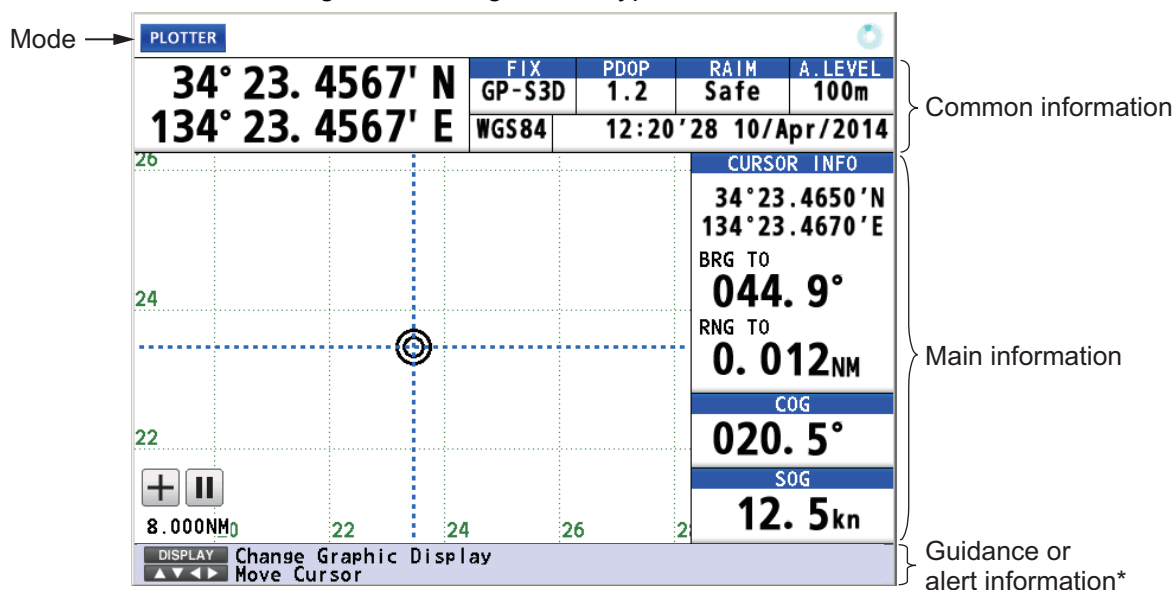

*: The alert information is displayed when an alert occurs.

1. OPERATIONAL OVERVIEW

Plotter Display

This icon appears when the number of satellites used for positioning is more than four and the high precision speed computing is available.

This icon appears during the synchronization with ECDIS.

Distance for RAIM reliability
HDOP: 2D
PDOP: 3D

Spinner rotates when the equipment is functioning normally.

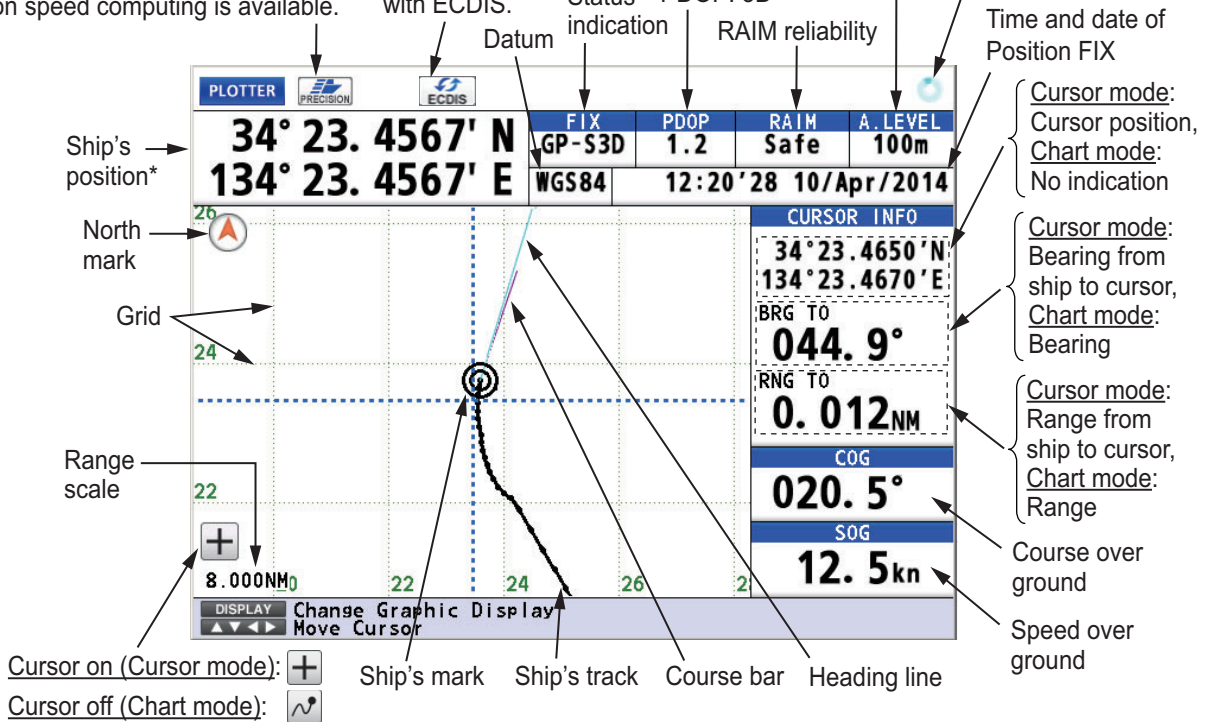

*: Shows the ship's position adjusted with the setting position offset based on the selected datum (refer to paragraph 9.3.5).

Note: The color of the ship's position data depends on positioning status.

Black: GPS and/or GLONASS position fix

Red: No GPS and/or GLONASS position fix

Sat view Display

Satellites used for positioning (Satellite numbers used for positioning are displayed in white, or black if not used for positioning.)

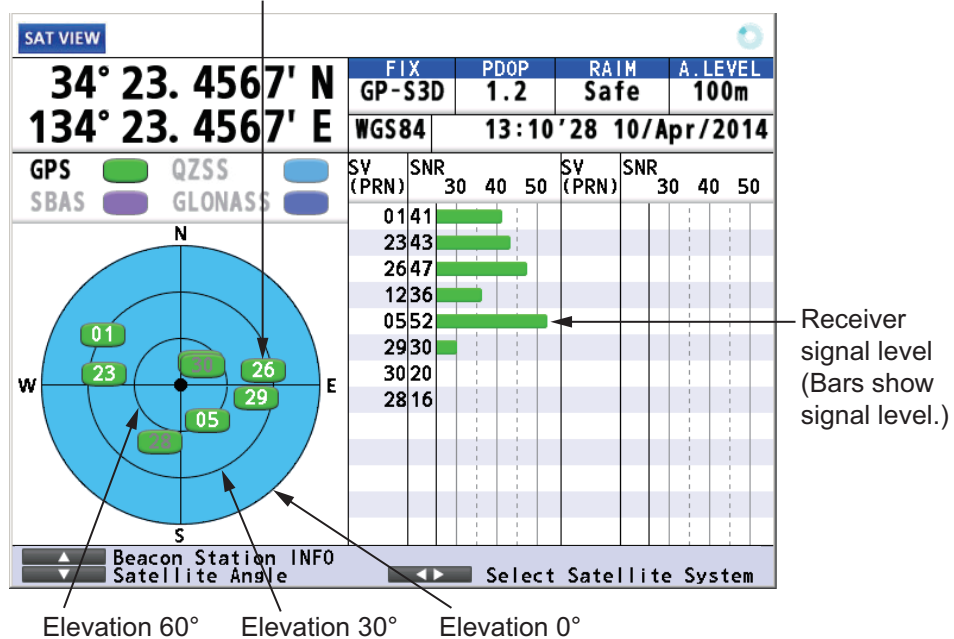

Highway Display

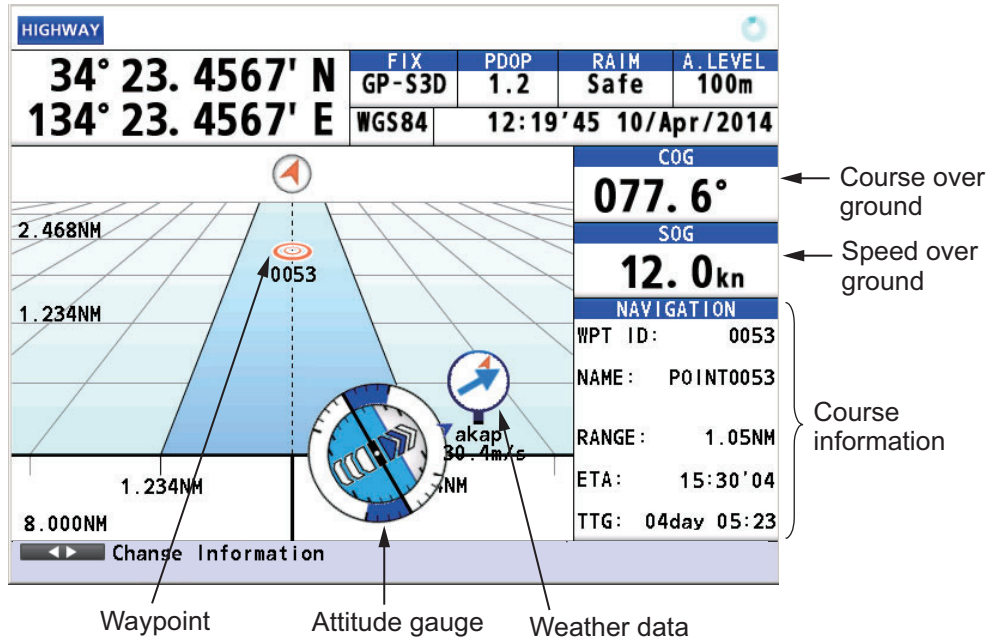

Course Display

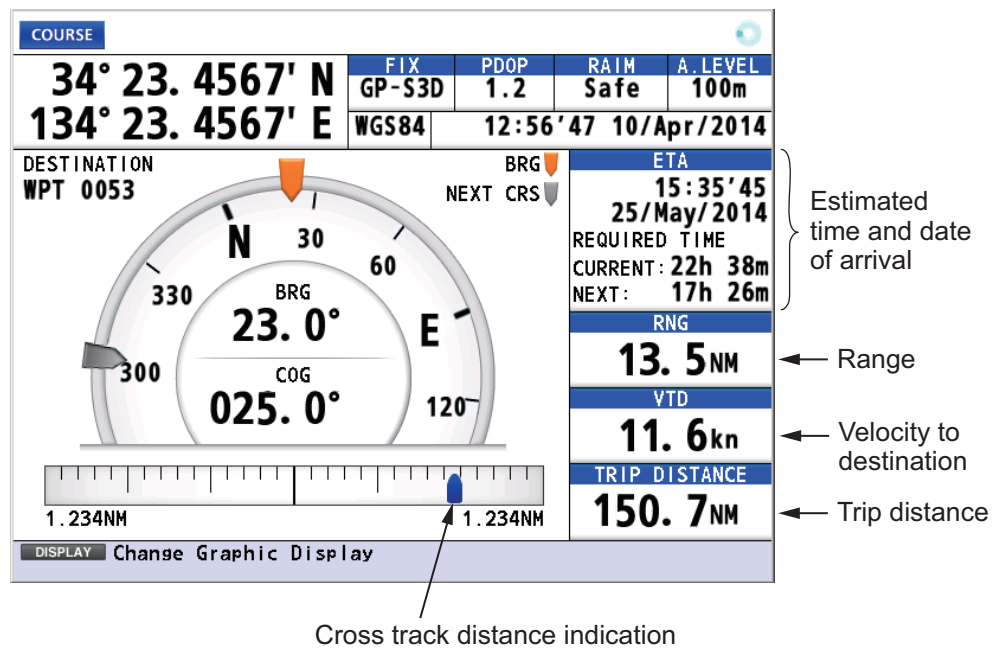

Data Display

DATA			
FIX GP-S3D	PDOP 1.2	RAIM Safe	A. LEVEL 100m
WGS84 34°23.4567'N 134°23.4567'E		TIME AND DATE UTC 13:57'47 10/Apr/2014	
RNG 31.23_{NM}		SOG 13.4_{kn}	
HDG 123.4°		COG 123.4°	
NAVIGATION Destination WPT NO.0056 POINT0056			
Next WPT WPT NO.0057 POINT0057			
Change Data to Display CURSOR ON/OFF Select Box to Zoom in			

Note: When invalid data is input, “----” is displayed.

1.5 Main Menu Overview

1. Press the **MENU/ESC** key to open the main menu.

MENU				
WGS84	34°23.4567'N	134°23.4567'E	GP-S3D	Safe
MENU				
1	Display	▶		
2	Track/Mark	▶		
3	Navigation	▶		
4	Notice Setting	▶		
5	Alert	▶		
6	Maintenance	▶		
7	I/O	▶		
8	System Setting	▶		
0-9 Select Item ▲▼ Select Active Item ▶ Go to Next ◀ Back MENU/ESC Close				

These marks indicate additional menus.

Basic operation or alert information

2. Use the cursorpad (▲ or ▼) to select a menu item then press the **NU/CU ENT** key. You can also select a menu item by pressing the numeric keys. This manual states this operating procedure as “Select [No. menu name].” The menu items that have a ▶ indicate additional menus.

MENU				
WGS84	34°23.4567'N	134°23.4567'E	GP-S3D	Safe
MENU				
1	Display	▶		
2	Track/Mark	▶		
3	Navigation	▶		
4	Notice Setting	▶		
5	Alert	▶		
6	Maintenance	▶		
7	I/O	▶		
8	System Setting	▶		
0-9 Select Item ▲▼ Select Active Item ▶ Go to Next ◀ Back MENU/ESC Close				

Second layer

MENU				
WGS84	34°23.4567'N	134°23.4567'E	GP-S3D	Safe
MENU				
Display				
1	Display	▶		
2	Track/Mark	▶		
3	Navigation	▶		
4	Notice Setting	▶		
5	Alert	▶		
6	Maintenance	▶		
7	I/O	▶		
8	System Setting	▶		
0-9 Select Item ▲▼ Select Active Item ▶ Go to Next ◀ Back MENU/ESC Close				

Third layer

3. Select an option.
4. Press the **MENU/ESC** key to close the main menu.

1.6 List Overview

The **LIST** key displays the mark list, route list and station list, in the sequence shown below.

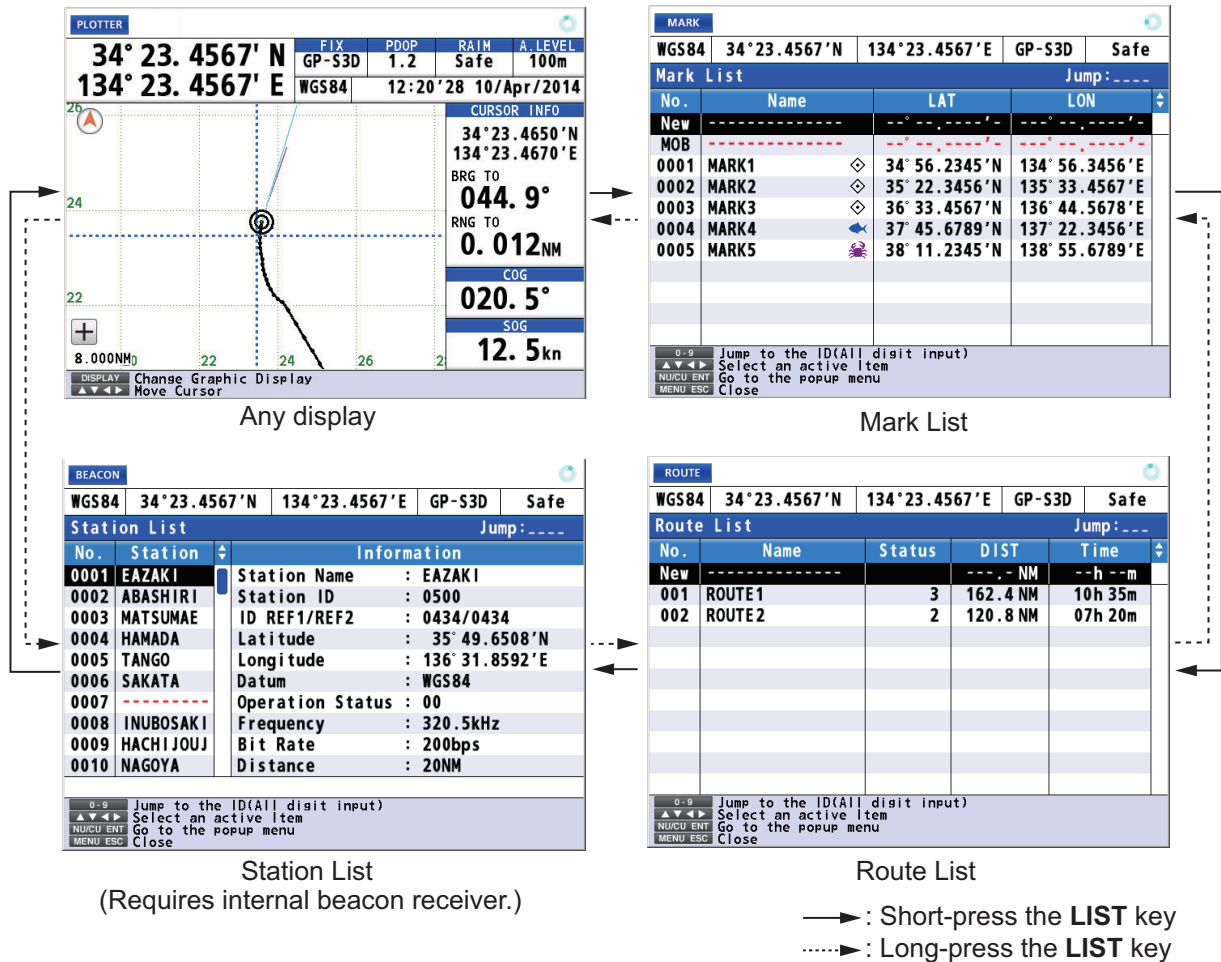

How to save position in a list

1. Press the **MENU/ESC** key to open the main menu.
2. Select [8 System Setting] then [2 Plotter].
3. Select [7 List Number].
4. Select [1 Keeping] or [2 Not Saved].
 [Keeping]: Saves position in lists.
 [Not Saved]: No. 0001 is always displayed at the top of the list.
5. Press the **MENU/ESC** key to close the main menu.



1. OPERATIONAL OVERVIEW

How to change the data to display on the mark list

1. Press the **MENU/ESC** key to open the main menu.
2. Select [8 System Setting] then [2 Plotter].
3. Select [8 List Information].
4. Select [1 L/L] or [2 Range/Bearing].
[L/L]: Displays latitude and longitude.
[Range/Bearing]: Displays the bearing and distance from own ship to a mark or a waypoint.
5. Press the **MENU/ESC** key to close the main menu.



MARK				
WGS84	34°23.4567'N	134°23.4567'E	GP-S3D	Safe
Mark List				
No.	Name	LAT	LON	Jump
New				
MOB				
0001	MARK1	34° 56.2345'N	134° 56.3456'E	
0002	MARK2	35° 22.3456'N	135° 33.4567'E	
0003	MARK3	36° 33.4567'N	136° 44.5678'E	
0004	MARK4	37° 45.6789'N	137° 22.3456'E	
0005	MARK5	38° 11.2345'N	138° 55.6789'E	

L/L

MARK				
WGS84	34°23.4567'N	134°23.4567'E	GP-S3D	Safe
Mark List				
No.	Name	Bearing	DIST	Jump
New				
MOB				
0001	MARK1	12.3 °	1.230 NM	
0002	MARK2	13.4 °	1.928 NM	
0003	MARK3	14.9 °	2.017 NM	
0004	MARK4	15.6 °	2.836 NM	
0005	MARK5	16.0 °	3.564 NM	

Range/Bearing

1.7 Context Menu Overview

When you select an object on the screen with the cursor, a context menu (list of available operations) is displayed. Select an appropriate operation from the context menu.

You can display a context menu for track, mark, route, waypoint or MOB. For example, do the following to open the context menu for a mark.

1. Press the **CURSOR ON/OFF** key to turn the cursor on.
2. Use the cursorpad to select a mark then press the  key. The context menu opens.

Edit	
1	GoTo/Cancel
2	Delete
3	Name : POINT0001
4	POS: 34° 14.6978'N 134° 16.8534'E
5	Symbol : ◇
6	Color :  White/Black

2. PLOTTER DISPLAY OVERVIEW, TRACK

2.1 How to Set the Display

2.1.1 How to select the background color

You can select the background color to suit lighting conditions or environment (see section 1.3).

1. Press the **MENU/ESC** key to open the main menu.
2. Select [1 Display] then [1 Back Ground].

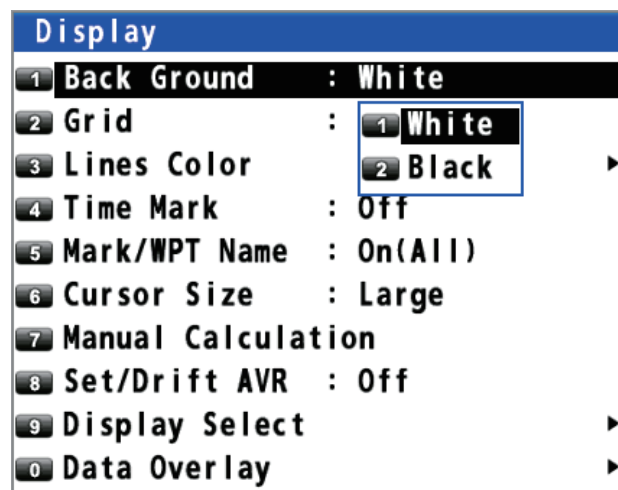

3. Select [1 White] or [2 Black].
4. Press the **MENU/ESC** key to close the main menu.

2.1.2 How to zoom in or out the display

You can change the range scale on the plotter display. Press the **ZOOM IN** key to zoom in the display and the **ZOOM OUT** key to zoom out the display. The horizontal range is available among 0.125, 0.25, 0.5, 1, 2, 4, 8, 16, 32, 64, 128, 256, 512 and 1024 NM.

2.1.3 How to change the display orientation

The display orientation for the plotter display can be selected to north-up or course-up. Press the **NU/CU ENT** key to change the display orientation.

North-up

True north (0°) is at the top of the display. Own ship moves on the display in accordance with true motion. The land is stationary.

Course-up

When the destination is set, the destination is at the top of the display and the north mark (⬆) appears at the left side of the display.

When the destination is not set, own ship's course is upward on the display at the moment you select the course-up and the north mark (⬆) appears at the left side of the display.

2.1.4 How to turn the cursor on/off, change cursor size

Press the **CURSOR ON/OFF** key to turn the cursor on or off.

Cursor size

You can change the cursor size.

1. Press the **MENU/ESC** key to open the main menu.
2. Select [1 Display] then [6 Cursor Size].



3. Select [1 Large] or [2 Small].

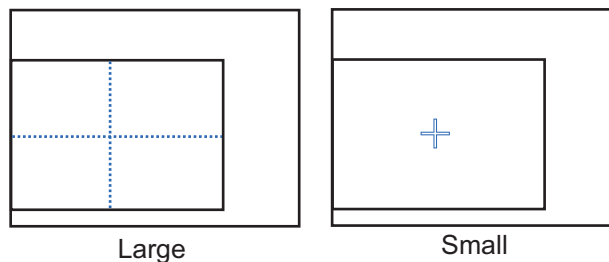

4. Press the **MENU/ESC** key to close the main menu.

2.1.5 How to move the cursor

You can move the cursor with the cursorpad.

1. Press the **CURSOR ON/OFF** key to turn the cursor on.
2. Press or hold down the cursorpad. The cursor moves in the direction of the arrow or diagonal. The display shifts when the cursor reaches an edge of the display, in the direction opposite of the arrow pressed on the cursorpad. When the cursor is turned on, the cursor position, the bearing and range from own ship to the cursor appear at the right side of the display (see the plotter display on page 1-6).

2.1.6 How to shift the display

You can shift the display on the plotter display.

1. Press the **CURSOR ON/OFF** key to turn the cursor off.
2. Press or hold down the cursorpad.

2.1.7 How to center the cursor position or ship's position

Cursor position

1. Press the **CURSOR ON/OFF** key to turn the cursor on.
2. Press the **CENTER** key.

Ship's position

1. Press the **CURSOR ON/OFF** key to turn the cursor off.
2. Press the **CENTER** key.

Note: When own ship reaches an edge of the display, own ship's mark is automatically centered.

2.1.8 How to show or hide the grid and change its color

You can show or hide the grid and change its color (see "Plotter Display" on page 1-6).

1. Press the **MENU/ESC** key to open the main menu.
2. Select [1 Display] then [2 Grid].



3. Select the grid color. To turn the grid off, select [8 Off]. When selecting [7 White/Black], the grid color depends on the background color.

Background color	Grid color
White	Black
Black	White

4. Press the **MENU/ESC** key to close the main menu.

2.1.9 How to show or hide the XTL line and change its color

The XTL lines (see the illustration on page 5-1) straddle the intended course line and they mark the XTL range. You can show or hide the lines and change their color.

1. Press the **MENU/ESC** key to open the main menu.
2. Select [1 Display] then [3 Lines Color].

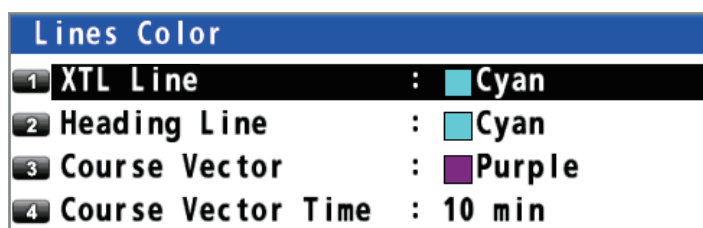

2. PLOTTER DISPLAY OVERVIEW, TRACK

3. Select [1 XTL Line].
4. Select the XTL line color. To turn the XTL line off, select [8 Off].
5. Press the **MENU/ESC** key to close the main menu.

2.1.10 How to show or hide the heading line and change its color

You can show or hide the heading line and change its color.

1. Press the **MENU/ESC** key to open the main menu.
2. Select [1 Display] then [3 Lines Color].
3. Select [2 Heading Line].
4. Select the heading line color. To turn the heading line off, select [8 Off].
5. Press the **MENU/ESC** key to close the main menu.

2.1.11 How to set the COG vector

The COG vector is a vector line that runs from own ship's icon. This vector shows speed and course of own ship. The top of a vector shows estimated position of own ship after the selected vector time elapses.

Note: The COG vector is not displayed when there is no position data.

How to show or hide the COG vector and change its color

1. Press the **MENU/ESC** key to open the main menu.
2. Select [1 Display] then [3 Lines Color].
3. Select [3 Course Vector].
4. Select the COG vector color. To turn the COG vector off, select [8 Off].
5. Press the **MENU/ESC** key to close the main menu.

How to set the COG vector time

1. Press the **MENU/ESC** key to open the main menu.
2. Select [1 Display] then [3 Lines Color].
3. Select [4 Course Vector Time].
4. Select the time for the COG vector. If you select [9 Continuous], the COG vector extends to the edge of the display.
5. Press the **MENU/ESC** key to close the main menu.

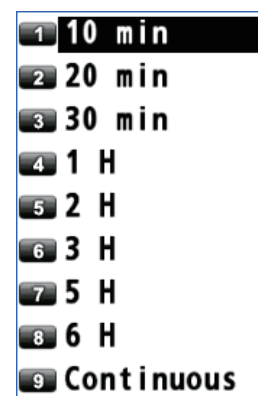

2.1.12 How to display the time mark

You can display the time mark on the track every hour on the hour.

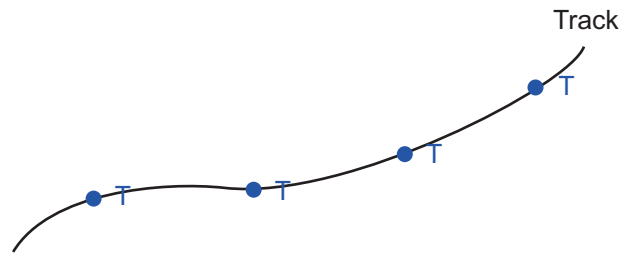

1. Press the **MENU/ESC** key to open the main menu.
2. Select [1 Display] then [4 Time Mark].
3. Select the color for the time mark. To turn the time mark off, select [8 Off].
4. Press the **MENU/ESC** key to close the main menu.

2.1.13 How to display the names for marks and waypoints

You can display the names for marks and waypoints.

1. Press the **MENU/ESC** key to open the main menu.
2. Select [1 Display] then [5 Mark/WPT Name].
3. Select [1 On (All)], [2 On (WPT)] or [3 Off].
 [On (All)]: Displays the names for marks and waypoints.
 [On (WPT)]: Displays the waypoint names.
 [Off]: Turns off the names.
4. Press the **MENU/ESC** key to close the main menu.

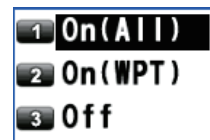

2.1.14 How to show or hide the weather data

You can display the direction and the speed of the wind analyzed from type 16/36 message when the weather data is received from a beacon station (see page 7-2).



Plotter display



Highway display

The arrow points in wind direction and its length changes according to wind speed.

Note: This menu requires internal or external DGPS/DGLONASS beacon receiver.

1. Press the **MENU/ESC** key to open the main menu.
2. Select [1 Display] then [0 Data Overlay].
3. Select [1 Weather (Type16/36)], then [1 On] or [2 Off].
 [On]: Displays the weather data (type 16/36 message) on the plotter display.
 [Off]: Turns off the weather data (type 16/36 message) on the plotter display.
Note: On the highway display, the weather data is displayed regardless of on/off.
4. Press the **MENU/ESC** key to close the main menu.

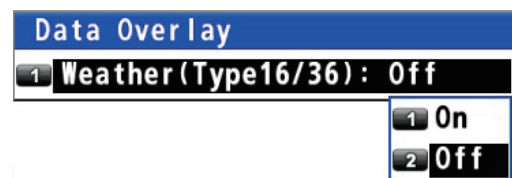

2.2 Bearing Reference

Ship's course and bearing to a waypoint are displayed in true or magnetic bearing. Magnetic bearing is true bearing plus (or minus) earth's magnetic variation.

2.2.1 How to select bearing reference

The default setting displays true bearing.

1. Press the **MENU/ESC** key to open the main menu.
2. Select [8 System Setting] then [2 Plotter].

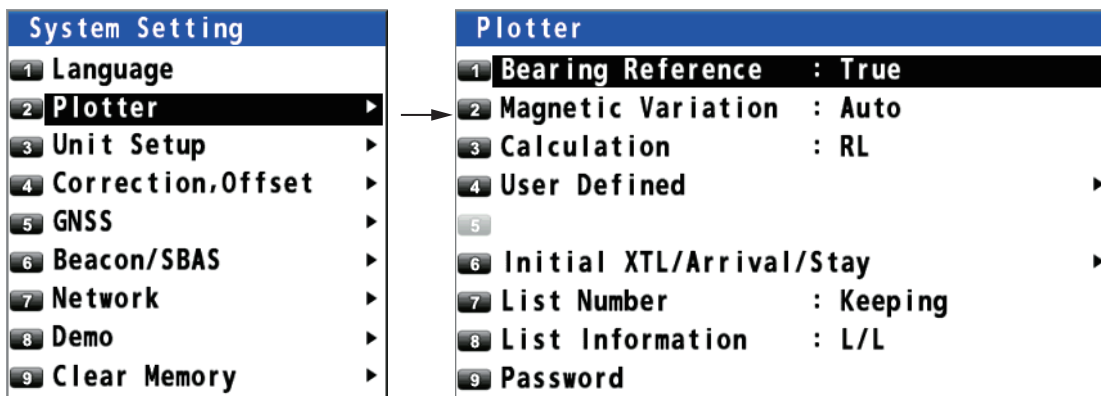

3. Select [1 Bearing Reference].
4. Select [1 True] or [2 Magnetic].
[True]: Gyrocompass or satellite compass using true bearing
[Magnetic]: Magnetic compass
5. Press the **MENU/ESC** key to close the main menu.
When selecting [2 Magnetic] at step 4, follow the steps at subsection 2.2.2.



2.2.2 How to set the magnetic variation

The location of the magnetic north pole is different from the geographical north pole. This causes a difference between the true and magnetic north direction. This difference is called magnetic variation, and varies with respect to the observation point on the earth. Magnetic variation is entered automatically or manually.

1. Press the **MENU/ESC** key to open the main menu.
2. Select [8 System Setting] then [2 Plotter].
3. Select [2 Magnetic Variation].
4. Select [1 Auto] or [2 Manual]. If you select [1 Auto], go to step 7.
For [2 Manual], go to step 5.
5. Enter the variation with the numeric keys. To change the coordinate, select "E" then press one of keys from 0 to 9.
6. Move the cursor to [Enter] then press the **NU/CU ENT** key.
7. Press the **MENU/ESC** key to close the main menu.

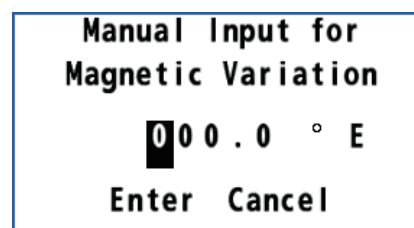

2.3 About Tracks

The GP-170 stores 1,000 points of track.

2.3.1 How to start or stop plotting and recording of the track

Press the **PLOT ON/OFF** key to start or stop plotting and recording of the track. The pop-up message "Resuming Track Plot" or "Stopping Track Plot" appears at the left side of the display for two seconds. When track plotting is stopped, the  icon appears at the bottom left corner of the display.

2.3.2 How to set the track plotting interval

In drawing the track, the position of your ship is stored into the memory of this equipment at an interval of time or distance. A shorter interval provides better reconstruction of the track, but the storage time of the track is reduced. When the track memory becomes full, the oldest track is erased to make room for the latest.

1. Press the **MENU/ESC** key to open the main menu.
2. Select [2 Track/Mark] then [1 Track REC].

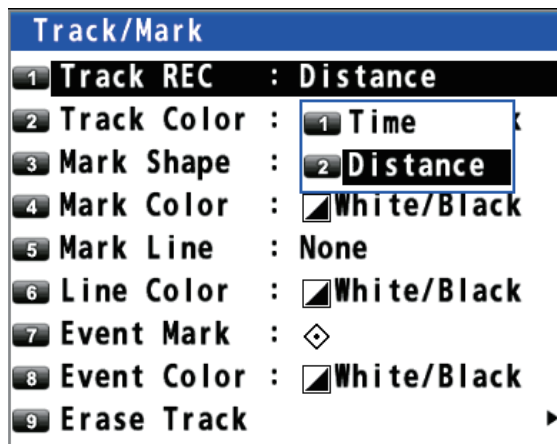

3. Select [1 Time] or [2 Distance].
 [Time]: Enter the time interval with the numeric keys (setting range: 0001 (1 sec) to 6000 (60 min)).
 [Distance]: Enter the distance interval with the numeric keys (setting range: 00.01 to 99.99 NM).

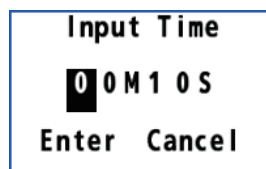

Time

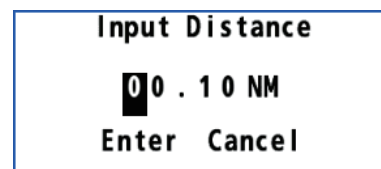

Distance

4. Move the cursor to [Enter] then press the **NU/CU ENT** key.
5. Press the **MENU/ESC** key to close the main menu.

2.3.3 How to set the track color

You can select the track color as follows:

1. Press the **MENU/ESC** key to open the main menu.
2. Select [2 Track/Mark] then [2 Track Color].
3. Select the track color.
4. Press the **MENU/ESC** key to close the main menu.

How to change the color of selected track

1. Put the cursor on the track.
2. Press the  key to open the context menu.



3. Select [1 Color].
4. Select the color to change.
5. Press the **MENU/ESC** key to close the context menu.

2.3.4 How to erase the track

How to erase all tracks from the main menu

1. Press the **MENU/ESC** key to open the main menu.
2. Select [2 Track/Mark] then [9 Erase Track].



3. Select [1 Erase Track]. The confirmation message appears.

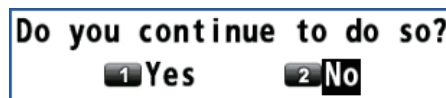

4. Select [1 Yes].
5. Press the **MENU/ESC** key to close the main menu.

How to erase all tracks from the context menu

1. Put the cursor on a track.
2. Press the  key to open the context menu.
3. Select [2 Erase All]. The confirmation message appears.
4. Select [1 Yes].

3. MARKS

You can put marks on the plotter display to indicate good fishing spot, location of traps, etc. Marks have 16 shapes and seven colors. Also, marks can be connected with lines.

3.1 How to Enter a Mark on the Plotter Display

3.1.1 How to preset mark appearance

Set the default mark shape, color, line type to use when entering a mark.

Mark shape

You can select a mark shape from 16 types.

1. Press the **MENU/ESC** key to open the main menu.
2. Select [2 Track/Mark] then [3 Mark Shape].



3. Use the cursorpad to select the shape then press the **NU/CU ENT** key.
4. Press the **MENU/ESC** key to close the main menu.

Mark color

You can select a mark color from seven colors.

1. Press the **MENU/ESC** key to open the main menu.
2. Select [2 Track/Mark] then [4 Mark Color].



3. Select the color.
4. Press the **MENU/ESC** key to close the main menu.

Mark line

Marks can be connected with lines, and three types of lines are available.

1. Press the **MENU/ESC** key to open the main menu.

3. With the cursor on the [New] line, press the **NU/CU ENT** key.



4. Select [1 Cursor].
 5. Use the cursorpad to select the position for the mark.
 6. Press the **NU/CU ENT** key.

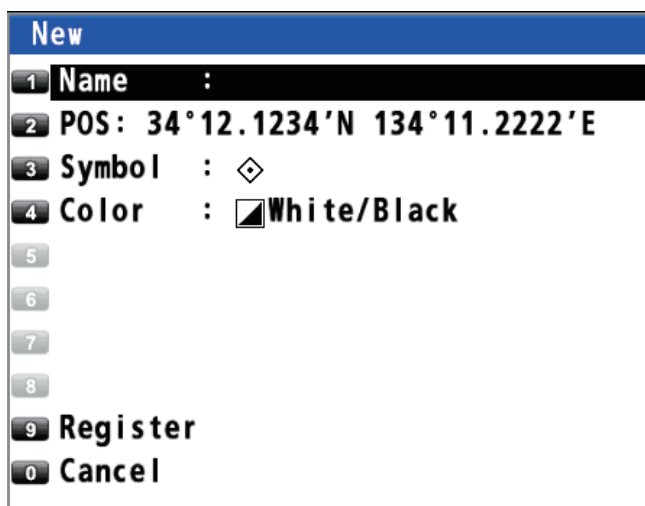

7. Change the name (see page 4-6), position, symbol or color if necessary.
 8. Select [9 Register]. The confirmation message appears.



9. Select [1 Yes] or [2 No].
 [Yes]: Marks are registered with connection lines.
 [No]: Marks are registered without connection lines.
 10. Press the **MENU/ESC** key to close the main menu.

By entering L/L

1. Press the **MENU/ESC** key to open the main menu.
 2. Select [3 Navigation] then [1 Mark Registration].
 3. With the cursor on the [New] line, press the **NU/CU ENT** key.

3. MARKS

4. Select [2 Input L/L].

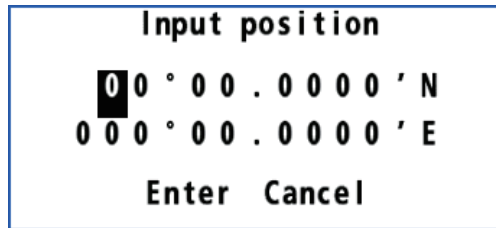

5. Enter latitude and longitude with the numeric keys. (To change the coordinate, select "N" or "E" then press one of keys from 0 to 9.)
6. Move the cursor to [Enter] then press the **NU/CU ENT** key.

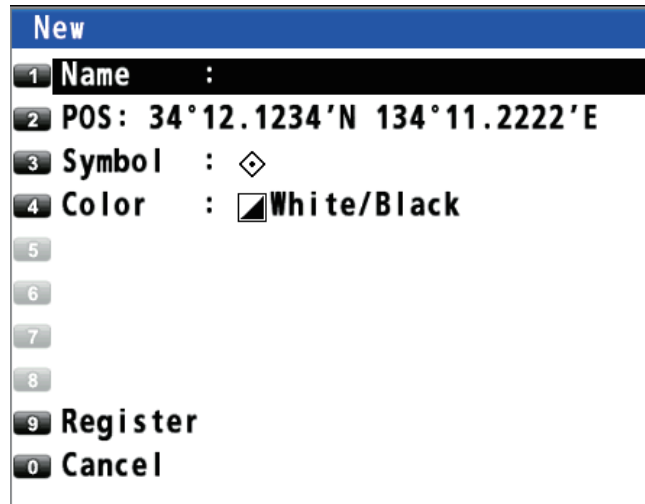

7. Change the name (see page 4-6), position, symbol or color if necessary.
8. Select [9 Register]. The confirmation message appears.



9. Select [1 Yes] or [2 No].
[Yes]: Marks are registered with connection lines.
[No]: Marks are registered without connection lines.
10. Press the **MENU/ESC** key to close the main menu.

3.2 How to Enter an Event Mark

Event marks can be used to mark an important present position on the plotter display.

3.2.1 How to preset event mark appearance

Set the default event mark shape and color to use when entering an event mark.

Event mark shape

You can select an event mark shape from 16 types.

1. Press the **MENU/ESC** key to open the main menu.
2. Select [2 Track/Mark] then [7 Event Mark].



3. Use the cursorpad to select the shape then press the **NU/CU ENT** key.
4. Press the **MENU/ESC** key to close the main menu.

Event mark color

You can select an event mark color from seven colors.

1. Press the **MENU/ESC** key to open the main menu.
2. Select [2 Track/Mark] then [8 Event Color].



3. Select the color.
4. Press the **MENU/ESC** key to close the main menu.

3.2.2 How to enter an event mark at own ship's position

1. Press the **CURSOR ON/OFF** key to turn the cursor off.
2. Press the **MARK EVENT** key on the plotter display. This mark is named with the youngest unused mark number (for example, "POINT0001"), and saved to the mark list.

3.2.3 How to enter an event mark from the mark list

1. Press the **MENU/ESC** key to open the main menu.
2. Select [3 Navigation] then [1 Mark Registration].
3. With the cursor on the [New] line, press the **NU/CU ENT** key.

3. MARKS

4. Select [3 OwnShip Position].

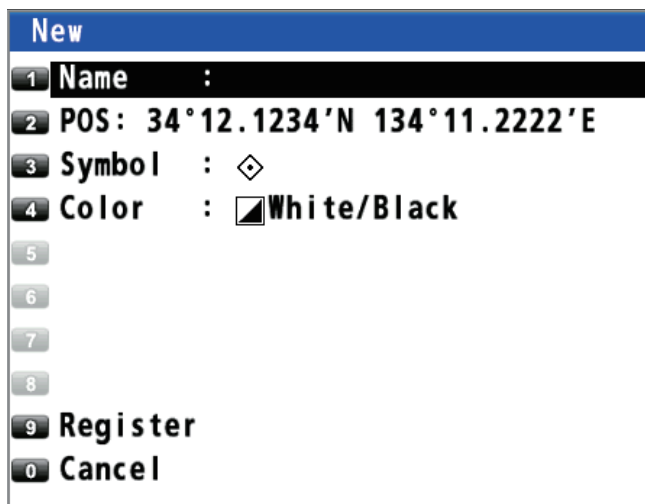

5. Change the name (see page 4-6), position, symbol or color if necessary.
6. Select [9 Register]. The confirmation message appears.



7. Select [1 Yes] or [2 No].
[Yes]: Marks are registered with connecting lines.
[No]: Marks are registered without connecting lines.
8. Press the **MENU/ESC** key to close the main menu.

3.3 How to Enter a MOB Mark

The MOB mark denotes man overboard position. You can use it as an aid to rescue.

Note: When the ECDIS synchronization is on, a MOB mark can not be entered from the GP-170 (see section 9.8).

Press the **MOB** key to put a MOB mark on any display. When the key is pressed, own ship's position is registered as a MOB mark (). The following message appears.

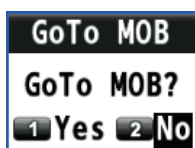

Select [1 Yes]. The position for the MOB mark becomes the destination. A line is drawn between own ship and the MOB mark. This line shows the shortest course to go to the MOB position. The bearing and range from own ship to the MOB position are displayed at the right of the display. Only one MOB mark can be put on the plotter display, and each time the **MOB** key is operated the previous MOB mark and its position data are written over.

3.4 How to Edit a Mark or an Event Mark

You can edit name, position, shape and color for a mark or an event mark on the plotter display or through the mark list.

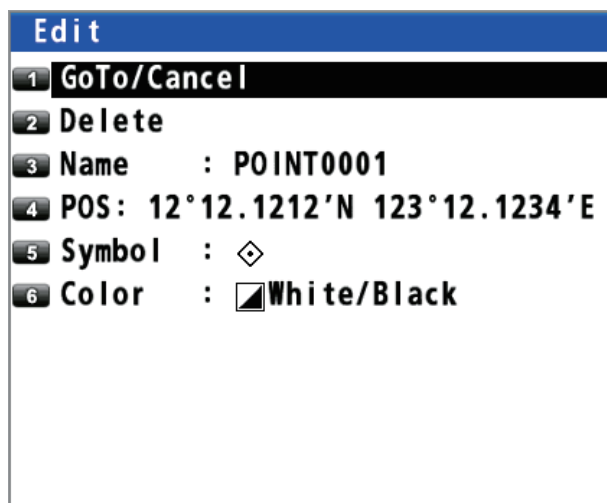

On the plotter display

1. Press the **CURSOR ON/OFF** key to turn the cursor on.
2. Use the cursorpad to select the (event) mark to edit then press the  key to open the context menu.



3. Select appropriate options to edit then set them.
4. Press the **MENU/ESC** key to close the context menu.

From the mark list

1. Press the **MENU/ESC** key to open the main menu.
2. Select [3 Navigation] then [1 Mark Registration].
3. Use the cursorpad ( or ) to select the (event) mark to edit then press the **NU/CU ENT** key. The [Edit] window same as above appears.

Note: You can select the (event) mark to edit by entering its mark no. with the numeric keys.

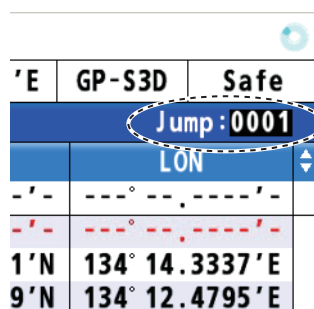

Enter the mark no. (e.g. "0001") with the numeric key then press the **NU/CU ENT** key.

4. Select appropriate options to edit then set them.
5. Press the **MENU/ESC** key to close the main menu.

3.5 How to Erase Marks

You can erase a mark(s), an event mark(s) or a MOB mark.

Note: You cannot erase the mark used as the current destination except the MOB mark.

How to erase a mark from the context menu

1. Press the **CURSOR ON/OFF** key to turn the cursor on.
2. Use the cursorpad to select the mark to erase then press the  key to open the context menu.
3. Select [2 Delete].

How to erase a mark with the ACK/DELETE key

1. Press the **CURSOR ON/OFF** key to turn the cursor on.
2. Use the cursorpad to select the mark to erase then press the **ACK/DELETE** key. The confirmation message appears.
3. Select [1 Yes].

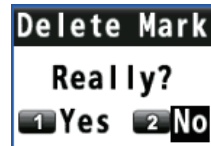

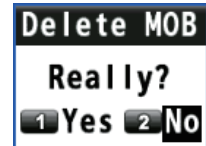

For (event) mark



For MOB mark

How to erase a mark from the mark list

Note: This menu is not available for a MOB mark.

1. Press the **MENU/ESC** key to open the main menu.
2. Select [3 Navigation] then [1 Mark Registration].
3. Use the cursorpad ( or ) to select the mark to erase then press the **NU/CU ENT** key.
4. Select [2 Delete].
5. Press the **MENU/ESC** key to close the main menu.

How to erase all marks

Note: This menu is not available for a MOB mark.

1. Press the **MENU/ESC** key to open the main menu.
2. Select [2 Track/Mark] then [9 Erase Track].



3. Select [2 Erase Mark]. The confirmation message appears.



4. Select [1 Yes].
5. Press the **MENU/ESC** key to close the main menu.

4. ROUTES

To navigate from one place to another, several course changes are required. The point for course change is called a waypoint. The sequence of waypoints (marks for course changes) leading to the last destination is called a route.

4.1 How to Create a Route

A maximum of 99 routes can be created and a route can have a maximum of 1,000 waypoints.

4.1.1 How to preset the settings for routes

XTL (Cross-track limit) range

The XTL range is the maximum distance your boat is allowed to go off course before the XTE notice (see section 6.3) is given.

1. Press the **MENU/ESC** key to open the main menu.
2. Select [8 System Setting] then [2 Plotter].

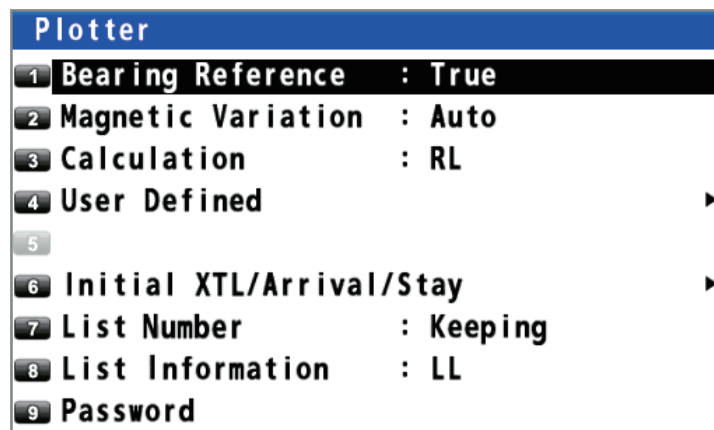

3. Select [6 Initial XTL/Arrival/Stay].

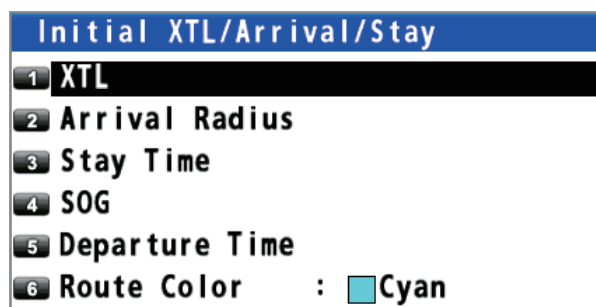

4. Select [1 XTL].
5. Enter the XTL distance with the numeric keys (setting range: 0.001 to 9.999 NM).
6. Move the cursor to [Enter] then press the **NU/CU ENT** key.
7. Press the **MENU/ESC** key to close the main menu.

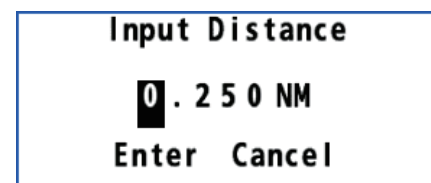

Arrival radius

You can receive an audiovisual notice when you are within the specified distance from a waypoint (see section 6.2).

1. Press the **MENU/ESC** key to open the main menu.
2. Select [8 System Setting] then [2 Plotter].
3. Select [6 Initial XTL/Arrival/Stay].
4. Select [2 Arrival Radius].
5. Enter the arrival radius with the numeric keys (setting range: 0.001 to 9.999 NM).
6. Move the cursor to [Enter] then press the **NU/CU ENT** key.
7. Press the **MENU/ESC** key to close the main menu.

Staying time

You can set the time the GP-170 waits at a waypoint in a followed route before it switches to the next waypoint. See the note in "Departure time" on this page.

1. Press the **MENU/ESC** key to open the main menu.
2. Select [8 System Setting] then [2 Plotter].
3. Select [6 Initial XTL/Arrival/Stay].
4. Select [3 Stay Time].
5. Enter the staying time at the waypoint with the numeric keys.
6. Move the cursor to [Enter] then press the **NU/CU ENT** key.
7. Press the **MENU/ESC** key to close the main menu.

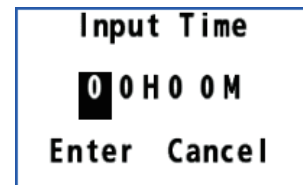

SOG

Set the speed to use to follow a route.

1. Press the **MENU/ESC** key to open the main menu.
2. Select [8 System Setting] then [2 Plotter].
3. Select [6 Initial XTL/Arrival/Stay].
4. Select [4 SOG].
5. Enter the speed with the numeric keys.
6. Move the cursor to [Enter] then press the **NU/CU ENT** key.
7. Press the **MENU/ESC** key to close the main menu.

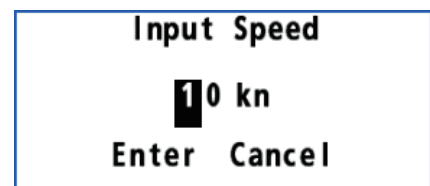

Departure time

You can set the date and time to depart from the waypoint on the route.

Note: When the departure date and time set is before the current date and time, the staying time has priority. When the departure date and time set is after the current date and time, the departure time has priority.

1. Press the **MENU/ESC** key to open the main menu.

2. Select [8 System Setting] then [2 Plotter].
3. Select [6 Initial XTL/Arrival/Stay].
4. Select [5 Departure Time].
5. Enter the date and time departing from the starting point with the numeric keys.
6. Move the cursor to [Enter] then press the **NU/CU ENT** key.
7. Press the **MENU/ESC** key to close the main menu.

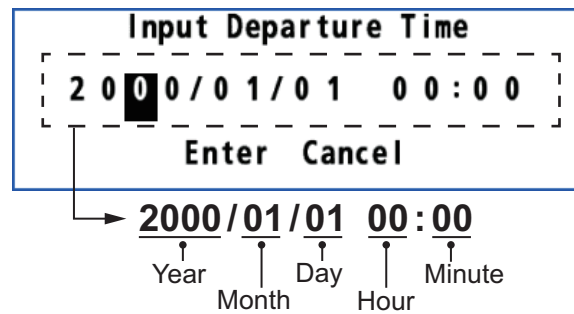

Range and bearing calculation method

When you set a destination, the equipment displays the range, bearing and course to the destination. Range and bearing are calculated by the Rhumb Line or Great Circle method.

1. Press the **MENU/ESC** key to open the main menu.
2. Select [8 System Setting] then [2 Plotter].
3. Select [3 Calculation].
4. Select [1 RL] or [2 GC].



[RL] (Rhumb Line): This method calculates the range and bearing between two points drawn on a nautical chart. Since the bearing is kept constant it is ideal for short-range navigation.

[GC] (Great Circle): This course line is the shortest course between two points on the surface of the earth, like stretching a piece of string between two points on earth. Frequent bearing changes are required to navigate by this method. For long-range navigation, divide the Great Circle route into several routes, and navigate each route by Rhumb Line.

5. Press the **MENU/ESC** key to close the main menu.

Route color

You can select the route color from seven colors.

1. Press the **MENU/ESC** key to open the main menu.
2. Select [8 System Setting] then [2 Plotter].
3. Select [6 Initial XTL/Arrival/Stay].
4. Select [6 Route Color].
5. Select a color for route lines and waypoints.
6. Press the **MENU/ESC** key to close the main menu.

4.1.2 How to create a new route with the cursor and the ROUTE key

1. Press the **CURSOR ON/OFF** key to turn the cursor on.
2. Long-press the **ROUTE** key. The message "Route Setting" appears on the display.
3. Use the cursorpad to place the cursor on the location for the first waypoint then press the **NU/CU ENT** key.

4. ROUTES

4. Use the cursorpad to place the cursor on the location for the next waypoint then press the **NU/CU ENT** key. Repeat this step to enter all waypoints.
5. At the last waypoint, press the **ROUTE** key to complete the route.

4.1.3 How to create a new route from the route list

With the cursorpad

1. Press the **MENU/ESC** key to open the main menu.
2. Select [3 Navigation] then [2 Route Registration].

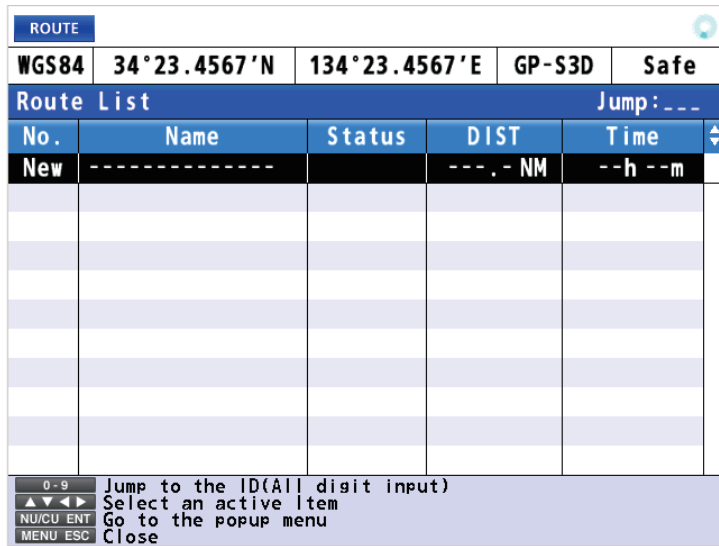

3. With the cursor on the [New] line, press the **NU/CU ENT** key.

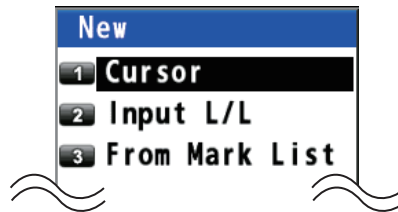

4. Select [1 Cursor].
5. Use the cursorpad to select the position for the first waypoint.
6. Press the **NU/CU ENT** key.

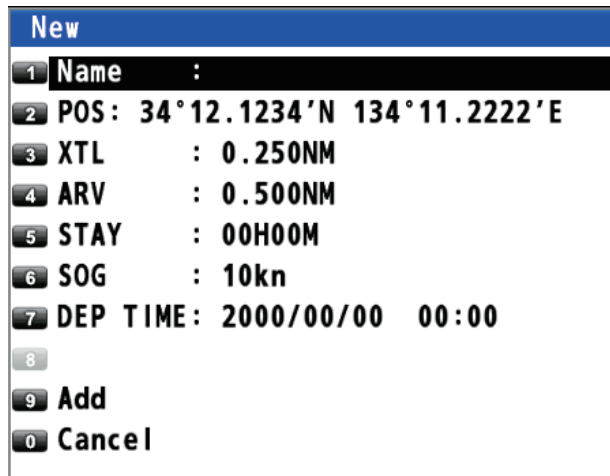

The values set in subsection 4.1.1 are displayed at the menu items [3 XTL] to [7 DEP TIME]. You can change these values for each waypoint if required.

7. Select [9 Add] to enter the waypoint.
8. Repeat steps 4 to 7 to enter all waypoints.
9. Press the **MENU/ESC** key to complete the route and close the main menu.

By entering L/L

1. Press the **MENU/ESC** key to open the main menu.
2. Select [3 Navigation] then [2 Route Registration].
3. With the cursor on the [New] line, press the **NU/CU ENT** key.
4. Select [2 Input L/L].
5. Enter latitude and longitude for the first waypoint with the numeric keys. (To change the coordinate, select "N" or "E" then press one of keys from 0 to 9.)
6. Move the cursor to [Enter] then press the **NU/CU ENT** key.
7. If necessary, change the settings of the route.
8. Select [9 Add] to enter the waypoint.
9. Repeat steps 4 to 8 to enter all waypoints.
10. Press the **MENU/ESC** key to complete the route and close the main menu.

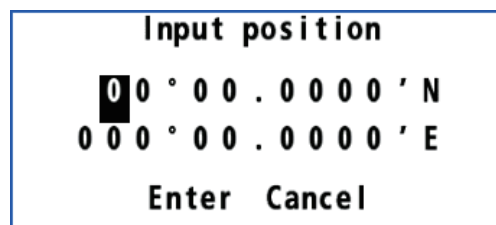

From the mark list

1. Press the **MENU/ESC** key to open the main menu.
2. Select [3 Navigation] then [2 Route Registration].
3. With the cursor on the [New] line, press the **NU/CU ENT** key.
4. Select [3 From Mark List] to show the mark list.

MARK				
WGS84	34°23.4567'N	134°23.4567'E	GP-S3D	Safe
Select Mark			Jump: ---	
		LAT	LON	
New	-----	--° --.-----'	--° --.-----'	
MOB	-----	-----	-----	
0001	POINT0001	38° 11.2345'N	137° 22.3456'E	
0002	POINT0002	37° 22.3456'N	136° 33.4567'E	
0003	POINT0003	36° 33.4567'N	135° 44.5678'E	
0004	POINT0004	34° 45.6789'N	134° 22.3456'E	
0005	POINT0005	32° 11.2345'N	132° 55.6789'E	
0006	POINT0006	39° 22.3456'N	138° 33.4567'E	
0007	POINT0007	39° 55.9876'N	138° 88.7654'E	
0008	POINT0008	35° 33.8765'N	134° 33.7654'E	
0009	POINT0009	34° 33.4567'N	134° 44.4567'E	

0-9 Jump to the ID(All digit input)
 ▲▼ Select an active Item
 NU/CU ENT Go to the popup menu
 MENU/ESC Close

5. Use the cursorpad (▲ or ▼) to select the mark to use for the route.
6. Press the **NU/CU ENT** key.
7. If necessary, change the settings of the route.
8. Select [9 Add] to enter the waypoint.
9. Repeat steps 4 to 8 to enter all waypoints.
10. Press the **MENU/ESC** key to complete the route and close the main menu.

4.2 How to Edit a Route

You can edit a route from the plotter display or through the route list.

4.2.1 How to change the route name or color

From the route list

1. Press the **MENU/ESC** key to open the main menu.
2. Select [3 Navigation] then [2 Route Registration] to display the route list.
3. Use the cursorpad (**▲** or **▼**) or enter the route no. at the "Jump" position to select the route to edit then press the **NU/CU ENT** key.

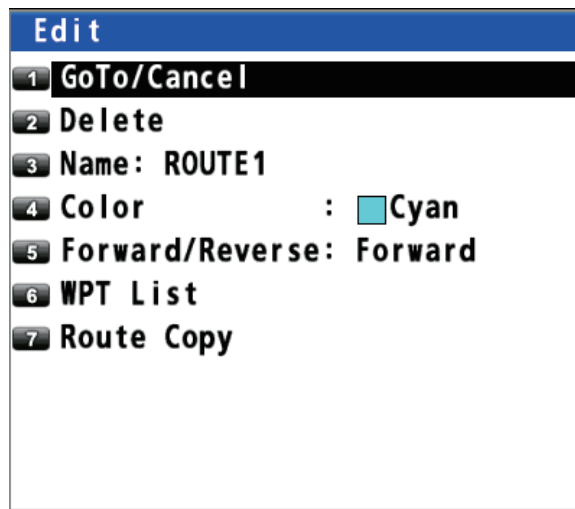

4. To change the name, select [3 Name].



To change input mode from English to Japanese, select [Jpn] then press the **NU/CU ENT** key.

5. To add characters, use the cursorpad to select a character to add then press the **NU/CU ENT** key.
To delete characters, use the cursorpad to select [BS] then press the **NU/CU ENT** key.
6. Use the cursorpad to select [Enter] then press the **NU/CU ENT** key.
7. To change the color, select [4 Color], then select the new color.
8. Press the **MENU/ESC** key to close the main menu.

On the plotter display

1. Press the **CURSOR ON/OFF** key to turn the cursor on.
2. Put the cursor on any route line of the route to edit then press the  key. The context menu opens.
3. Do steps 4 to 7 in "From the route list" on page 4-6 as appropriate.
4. Press the **MENU/ESC** key to close the context menu.

4.2.2 How to edit a waypoint in a route

1. Press the **CURSOR ON/OFF** key to turn the cursor on.
2. Use the cursorpad to select the waypoint in the route to edit then press the  key to open the context menu.

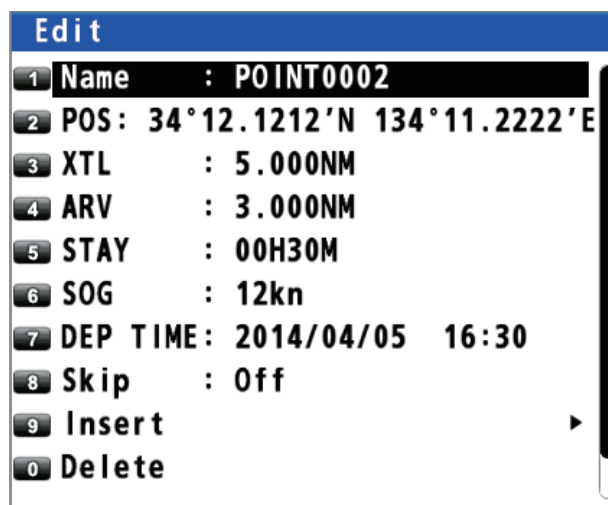

Note: If setting a waypoint at the own ship's position, the context menu for track edit is preferentially displayed when selecting the waypoint then pressing the  key (see section 2.3.3).

3. To change the name, select [1 Name].
4. To add characters, use the cursorpad to select a character to add then press the **NU/CU ENT** key.
To delete characters, use the cursorpad to select [BS] then press the **NU/CU ENT** key.
5. Use the cursorpad to select [Enter] then press the **NU/CU ENT** key.
6. To change the position, select [2 POS], then enter latitude and longitude for the waypoint with the numeric keys. (To change the coordinate, select "N" or "E" then press one of keys from **0** to **9**.)
7. Use the cursorpad to select [Enter] then press the **NU/CU ENT** key.
8. To change the XTL range scale, select [3 XTL], then enter the XTL range scale with the numeric keys.
9. Use the cursorpad to select [Enter] then press the **NU/CU ENT** key.
10. To change the arrival radius, select [4 ARV], then enter the arrival radius with the numeric keys.

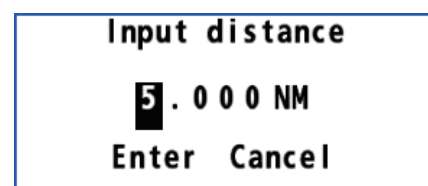

4. ROUTES

11. Use the cursorpad to select [Enter] then press the **NU/CU ENT** key.
12. To change the staying time, select [5 STAY], then enter the staying time at the waypoint with the numeric keys.
13. Use the cursorpad to select [Enter] then press the **NU/CU ENT** key.
14. To change the SOG, select [6 SOG], then enter the speed with the numeric keys.
15. Use the cursorpad to select [Enter] then press the **NU/CU ENT** key.
16. To change the departure time, select [7 DEP TIME], then enter the date and time departing from the waypoint with the numeric keys

Input time
00H30M
Enter Cancel

Input speed
12 kn
Enter Cancel

Input time
2014/04/05 16:30
Enter Cancel

17. Use the cursorpad to select [Enter] then press the **NU/CU ENT** key.
18. Press the **MENU/ESC** key to close the context menu.

4.2.3 How to temporarily deselect a waypoint in a route

You can temporarily deselect an unnecessary waypoint from a route. Using the route created in the illustration shown below as an example, deselect "POINT0003".

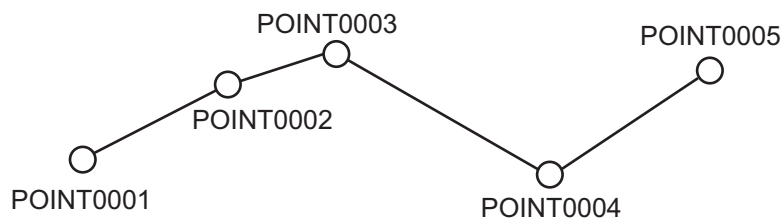

If you reconstruct the route without "POINT0003" it would look like the illustration below.

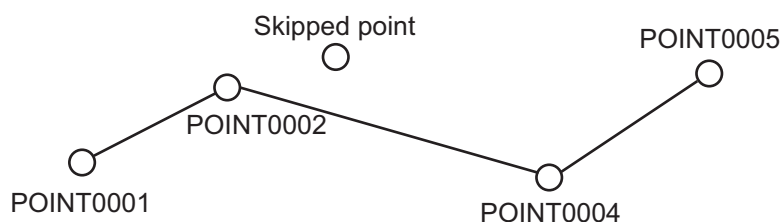

1. Press the **CURSOR ON/OFF** key to turn the cursor on.
2. Use the cursorpad to select the waypoint in the route to skip then press the  key. The context menu opens.
3. Select [8 Skip].
4. Select [2 On].
5. Press the **MENU/ESC** key to close the context menu.

How to erase a waypoint with the ACK/DELETE key

1. Press the **CURSOR ON/OFF** key to turn the cursor on.
2. Use the cursorpad to select the waypoint to delete then press the **ACK/DELETE** key. The confirmation message appears.
3. Select [1 Yes].

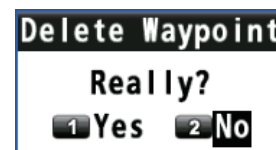



How to erase a waypoint from the route list

1. Press the **MENU/ESC** key to open the main menu.
2. Select [3 Navigation] then [2 Route Registration].
3. Use the cursorpad (**▲** or **▼**) to select the route no. which contains the waypoint to delete then press the **NU/CU ENT** key.
4. Select [6 WPT List].
5. Use the cursorpad (**▲** or **▼**) to select the waypoint to delete then press the **NU/CU ENT** key.
6. Select [0 Delete].
7. Press the **MENU/ESC** key to close the main menu.

4.2.5 How to insert a waypoint in a route

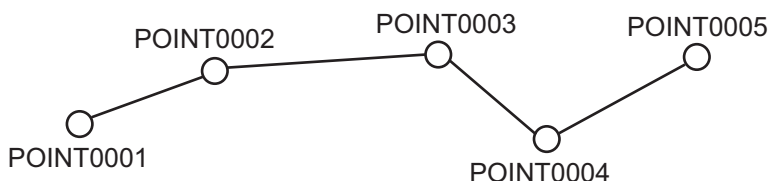
You can insert a waypoint backward or forward of the selected waypoint in a route. For example, to insert a waypoint backward or forward of "POINT0003", do the following:



1. Press the **CURSOR ON/OFF** key to turn the cursor on.
2. Use the cursorpad to select the waypoint (in this example, "POINT0003") then press the  key to open the context menu.
3. Select [9 Insert].



4. Select [1 Forward] or [2 Back].
 [Forward]: Insert a waypoint forward of the selected waypoint.
 [Back]: Insert a waypoint backward of the selected waypoint.



"Back" when selecting [2 Back].

5. Select [1 Cursor], [2 Input L/L] or [3 From Mark List].
6. Set a waypoint position refer to subsection 4.1.3. The context menu closes after selecting [9 Add].

4. ROUTES

- Select [7 Route Copy]. "ROUTE1" is copied in the illustration below.

[ROUTE1] is copied here. →

ROUTE				
WGS84	34°30.6204'N	134°13.7114'E	GP-S3D	Safe
Route List				Jump: ---
No.	Name	Status	DIST	Time
New	-----		---.- NM	--h --m
001	ROUTE1	5	117.5 NM	11h 45m
002	ROUTE2	3	37.72 NM	03h 46m
003	ROUTE1	5	117.5 NM	11h 45m

0-9 Jump to the ID(All digit input)
 ▲▼ Select an active item
 NU/CU ENT Go to the popup menu
 MENU ESC Close

- Edit the route as appropriate (see section 4.2).
- Press the **MENU/ESC** key to close the main menu.

4.3 How to Erase a Route

How to erase a route from the context menu

- Press the **CURSOR ON/OFF** key to turn the cursor on.
- Put the cursor on any route line of the route to delete then press the  key to open the context menu.

Edit	
1	GoTo/Cancel
2	Delete
3	Name: ROUTE1
4	Color :  Cyan
5	Forward/Reverse: Forward
6	WPT List
7	Route Copy

- Select [2 Delete].

How to erase a route from the route list

- Press the **MENU/ESC** key to open the main menu.
- Select [3 Navigation] then [2 Route Registration].
- Use the cursorpad (▲ or ▼) to select the route to delete then press the **NU/CU ENT** key.
- Select [2 Delete].
- Press the **MENU/ESC** key to close the main menu.

5. DESTINATION

Destination can be set five ways: by cursor, by waypoint, by mark, by route and by MOB position. The setting by MOB position is described in section 3.3. When setting a destination, a line (shortest course) appears between own ship and the destination selected.

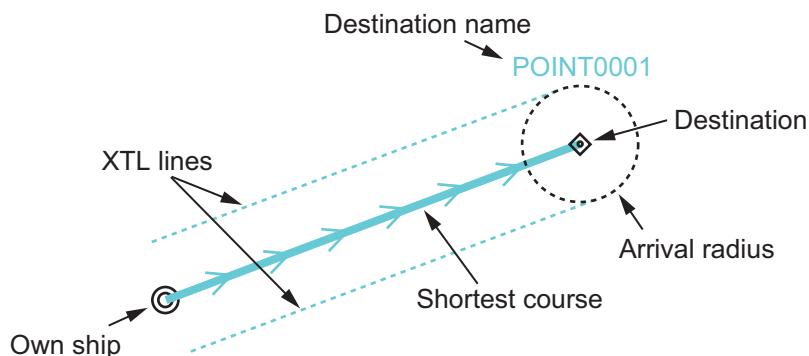

Note: When a destination is set, ETA and ETA(Plan) are displayed instead of COG and SOG at the bottom right of the plotter display with the cursor off.

ETA	
Route No. : 001	← Estimated time of arrival at destination
2014/04/10 14:20	
ETA(Plan)	
Route No. : 001	← Planned estimated time of arrival at destination
2014/04/10 14:01	

When setting a route as a destination

5.1 How to Set a Destination

Note: When the ECDIS synchronization is on, the destination can not be set on the GP-170 (see section 9.8).

5.1.1 How to set a cursor position as a destination

You can set a destination at the position selected with the cursor.

1. Press the **CURSOR ON/OFF** key to turn the cursor on.
2. Use the cursorpad to place the cursor on the location for a destination.
3. Press the **GO TO** key.

Note: This destination set is erased when a new destination is entered.

5.1.2 How to set a waypoint as a destination

You can set a waypoint as a destination.

1. Press the **CURSOR ON/OFF** key to turn the cursor on.
2. Use the cursorpad to place the cursor on a waypoint as a destination.
3. Press the  key to open the context menu.

5. DESTINATION

- Use the cursorpad to select [GoTo/Cancel] then press the **NU/CU ENT** key.

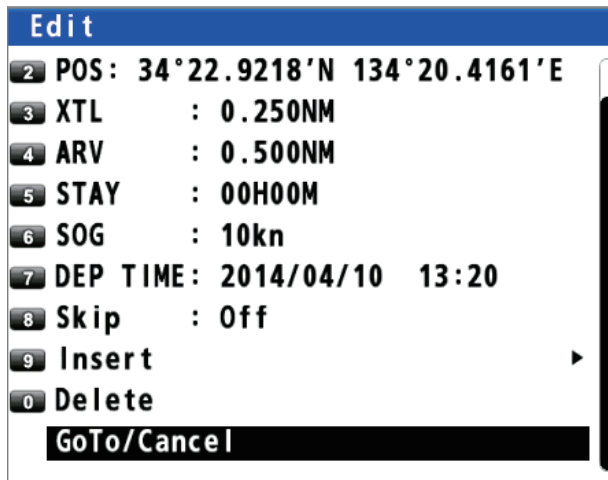

← Scroll bar (Indicates menus currently not shown in menu window. You can see the menus currently not shown by pressing the cursorpad (▲ or ▼.))

5.1.3 How to set a registered mark as a destination

You can set a registered mark as a destination.

From the main menu

- Press the **MENU/ESC** key to open the main menu.
- Select [3 Navigation] then [6 Goto (Mark Number)].

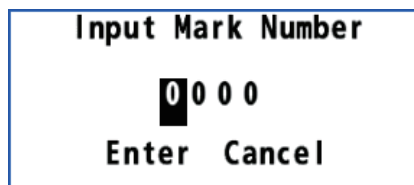

- Enter the mark number to set as a destination with the numeric keys.
- Move the cursor to [Enter] then press the **NU/CU ENT** key.
- Press the **MENU/ESC** key to close the main menu.

From the context menu

- Press the **CURSOR ON/OFF** key to turn the cursor on.
- Use the cursorpad to place the cursor on a mark as a destination.
- Press the  key to open the context menu.
- Select [1 GoTo/Cancel].

5.1.4 How to set a registered route as a destination

You can set a registered route as a destination.

From the main menu

1. Press the **MENU/ESC** key to open the main menu.
2. Select [3 Navigation] then [7 Goto (Route Number)].

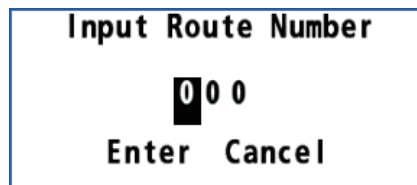

3. Enter the route number to set as a destination with the numeric keys.
4. Move the cursor to [Enter] then press the **NU/CU ENT** key.
5. Press the **MENU/ESC** key to close the main menu.

From the context menu

1. Press the **CURSOR ON/OFF** key to turn the cursor on.
2. Put the cursor on any route line of the route as a destination.
3. Press the  key to open the context menu.
4. Select [1 GoTo/Cancel].

5.2 How to Cancel a Destination

To cancel a destination, do one of the following three methods.

5.2.1 How to cancel a destination with the GO TO key

1. Press the **CURSOR ON/OFF** key to turn the cursor on.
2. Use the cursorpad to place the cursor on a destination.
3. Press the **GO TO** key.

5.2.2 How to cancel a destination from the main menu

1. Press the **MENU/ESC** key to open the main menu.
2. Select [3 Navigation] then [8 Goto Cancel].

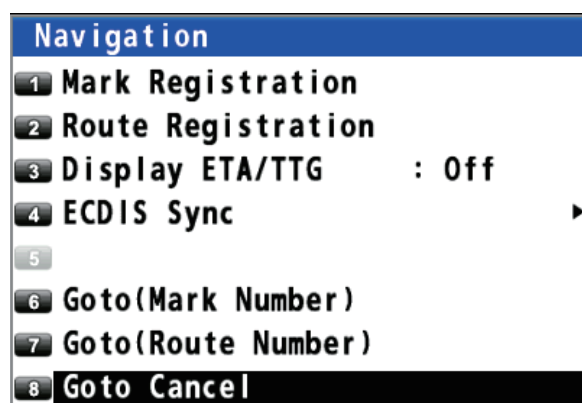

3. Press the **MENU/ESC** key to close the main menu.

5.2.3 How to cancel a destination from the context menu

Note: This procedure is not available for the destination set with a mark (excluding the MOB mark).

1. Press the **CURSOR ON/OFF** key to turn the cursor on.
2. Use the cursorpad to place the cursor on a destination.
3. Press the  key to open the context menu.

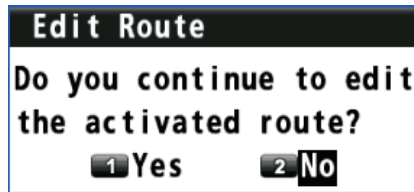

On a route line

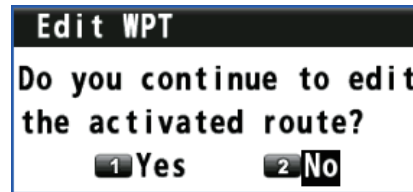

On a waypoint



On a MOB mark

4. For a route line or a waypoint, select [1 Yes] then [GoTo/Cancel]. For a MOB mark, select [1 GoTo/Cancel].

5.3 How to Calculate the Distance, Bearing and TTG (Time To Go) Between Two Points

You can display the distance, bearing and time to go between two points.

1. Press the **MENU/ESC** key to open the main menu.
2. Select [1 Display] then [7 Manual Calculation].

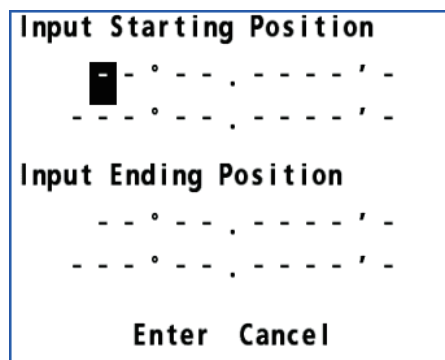

3. Enter latitude and longitude for the starting and ending positions with the numeric keys. To change the coordinate, select "N" or "E" then press one of keys from **0** to **9**.

- Move the cursor to [Enter] then press the **NU/CU ENT** key.

```

From: 12°34.5678'N 123°45.6789'E
To:   13°45.6789'N 134°56.7890'E
Distance:                658.49 NM
Bearing:                  083.8°
TTG(Manual):             02Day 17Hour 51Min
TTG(Estimated):          01Day 08Hour 55Min
OK

```

[TTG (Manual)]: Time to go calculated by SOG set on page 4-2

[TTG (Estimated)]: Time to go calculated by actual SOG

- Press the **NU/CU ENT** key then press the **MENU/ESC** key to close the main menu.

5.4 How to Display the ETA and TTG

You can display the ETA and TTG to waypoints on the plotter display.

ETA: The arrival date and time calculated by SOG set on page 4-2

TTG: The arrival date and time calculated by actual SOG (TTG is displayed when the SOG is 0.4 kn or above.)

When the departure date and time set is before the current date and time, the ETA and TTG are calculated by the staying time set. When the departure date and time set is after the current date and time, the ETA and TTG are calculated by the departure time set. See "Staying time" and "Departure time" on page 4-2.

- Press the **MENU/ESC** key to open the main menu.
- Select [3 Navigation] then [3 Display ETA/TTG].



- Select [1 Off], [2 ETA] or [3 ETA+TTG].

[Off]: Hides the ETA and TTG.

[ETA]: Shows the ETA.

[ETA+TTG]: Shows the ETA and TTG.

- Press the **MENU/ESC** key to close the main menu.

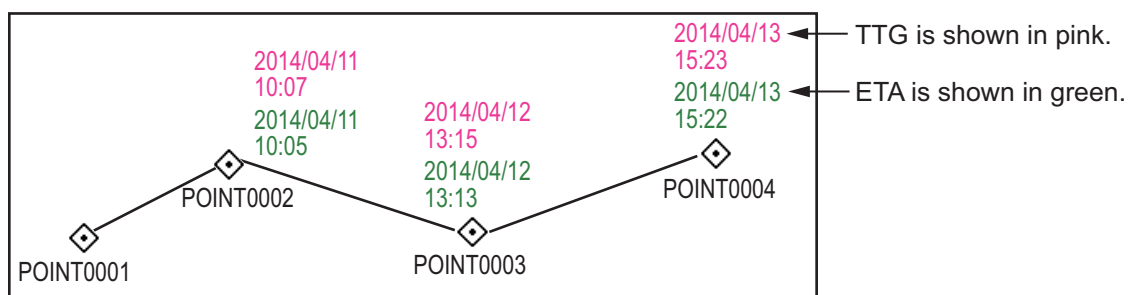

5.5 How to Calculate the Trip Distance

You can calculate the trip distance as follows:

1. Press the **MENU/ESC** key to open the main menu.
2. Select [4 Notice Setting] then [4 Trip].



3. Select [1 Status].



4. Select [1 Stop], [2 Start/Restart] or [3 Clear].
 [Stop]: Stops the trip distance calculation.
 [Start/Restart]*: Starts or restarts the trip distance calculation.
 [Clear]: Resets the trip distance.
5. Press the **MENU/ESC** key to close the main menu.

*: You can receive a notice, when your ship has traveled a preset distance. See section 6.5 for details.

5.6 How to Set the Drift

You can set the time for which the drift value is averaged. The longer the time setting, the more stable the drift value.

1. Press the **MENU/ESC** key to open the main menu.
2. Select [1 Display] then [8 Set/Drift AVR].

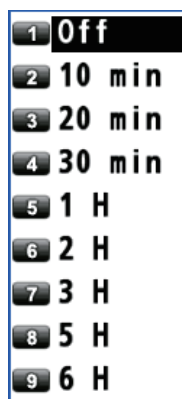

3. Select an option.
 [Off]: Displays the latest drift value.
 Others: Displays the average drift value per the setting time.
4. Press the **MENU/ESC** key to close the main menu.

6. NOTICES

There are five notice conditions which generate both audio and visual notices: Arrival, Anchor, XTE, Ship Speed, Trip and DC report (Satellite Report for Disaster and Crisis Management). When the conditions of a notice are met, the buzzer sounds according to the notice sound setting and the icon related to the notice turns from gray to blue at the top right-hand corner of the display.

You can silence the buzzer by pressing the **ACK/DELETE** key.

The screenshot shows a navigation display with the following data fields:

- PLOTTER** (top left)
- 34° 23. 4567' N** (Latitude)
- 134° 23. 4567' E** (Longitude)
- FIX GP-S3D** (Fix Name)
- WGS84** (Datum)
- PDOP 1.2** (Precision Dilution of Precision)
- RAIM Safe** (Receiver Autonomous Integrity Monitoring)
- A. LEVEL 100m** (Antenna Height)
- 12:20'28 10/Apr/2014** (Time and Date)
- CURSOR INFO** (Cursor Information):
 - 34° 23. 4650' N** (Cursor Latitude)
 - 134° 23. 4670' E** (Cursor Longitude)
 - BRG TO 044. 9°** (Bearing to cursor)
 - RNG TO 0. 012NM** (Range to cursor)
 - COG 020. 5°** (Course Over Ground)
 - SOG 12. 5kn** (Speed Over Ground)
- 8.000NM₀** (Scale)
- DISPLAY Change Graphic Display** (Bottom left)
- Move Cursor** (Bottom left)

Notice icons (top right):

- TRIP** (Trip)
- Speed** (Speed)
- Anchor** (Anchor)
- XTE** (XTE)
- Arrival** (Arrival)
- DC report** (DC report) (For icon type, see appendix 2.)
- SLAS QZSS** (Correcting by SLAS)

Note: You can not set both arrival and anchor notices at the same time.

6.1 Audio Notice Type

You can select the audio notice type as follows. When the conditions of a notice are met, the icon color related to the notice changes regardless of the audio notice type.

1. Press the **MENU/ESC** key to open the main menu.
2. Select [4 Notice Setting] then [9 Sound].

The screenshot shows the **Notice Setting** menu with the following options:

- 1 Arrival/Anchor : Off
- 2 XTE : Off
- 3 Ship Speed
- 4 Trip
- 5 DC Report
- 6
- 7
- 8
- 9 **Sound**

The **Sound** menu is shown with the following options:

- 1 **Notice Sound : Off**
- 2 **Key Sound : On**

6. NOTICES

3. Select [1 Notice Sound].
4. Select [1 Off], [2 On] or [3 Continuous].
[Off]: No sound, only visual notice (an icon turns blue)
[On]: Three long beeps and visual notice (related icon turns blue)
[Continuous]: This buzzer sounds until the **ACK/DELETE** key is operated to acknowledge the notice. Visual notice (related icon turns blue).
5. Press the **MENU/ESC** key to close the main menu.



6.2 Arrival/Anchor Notice

Note: You can not set both arrival and anchor notices at the same time.

6.2.1 Arrival notice

The arrival notice alerts you when you are within the specified distance from a destination waypoint.

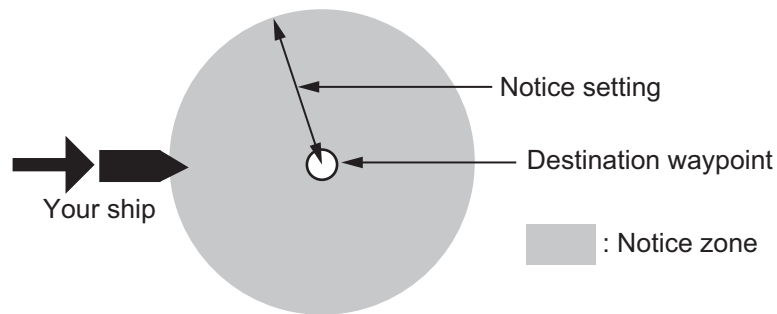

Before setting arrival notice, set the arrival radius (see "Arrival radius" on page 4-2).

1. Press the **MENU/ESC** key to open the main menu.
2. Select [4 Notice Setting] then [1 Arrival/Anchor].
3. Select [1 Arrival]. The arrival notice icon (📧) appears at the top right-hand corner of the display.
4. Press the **MENU/ESC** key to close the main menu.



To turn off the arrival notice, select [3 Off] at step 3.

6.2.2 Anchor notice

The anchor notice alerts you that your ship is moving when your ship should be at rest.

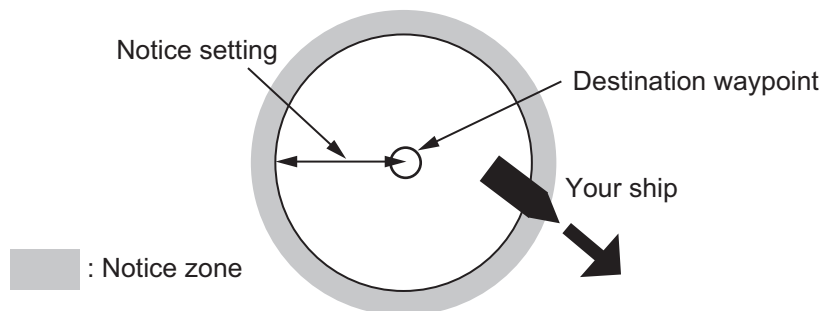

Before setting anchor notice, set the arrival radius (see "Arrival radius" on page 4-2).

1. Press the **MENU/ESC** key to open the main menu.
 2. Select [4 Notice Setting] then [1 Arrival/Anchor].
 3. Select [2 Anchor]. The anchor notice icon () appears at the top right-hand corner of the display.
 4. Press the **MENU/ESC** key to close the main menu.
- To turn off the anchor notice, select [3 Off] at step 3.

6.3 XTE Notice

The XTE (Cross-track error) notice alerts you when your ship is off its intended course (the line from the start point to the destination waypoint) by the distance specified.

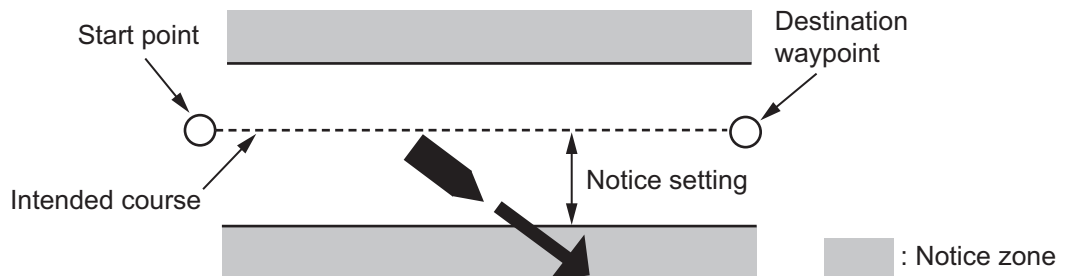

Before setting XTE notice, set the XTL range (see "XTL (Cross-track limit) range" on page 4-1).

1. Press the **MENU/ESC** key to open the main menu.
 2. Select [4 Notice Setting] then [2 XTE].
 3. Select [2 On]. The XTE notice icon () appears at the top right-hand corner of the display.
 4. Press the **MENU/ESC** key to close the main menu.
- To turn off the XTE notice, select [1 Off] at step 3.



6.4 Ship Speed Notice

The ship speed notice alerts you when your ship's speed is lower or higher than the speed notice setting or within the range set.

1. Press the **MENU/ESC** key to open the main menu.
2. Select [4 Notice Setting] then [3 Ship Speed].



3. Select [1 Status].



6. NOTICES

4. Select [2 In] or [3 Out]. The ship speed notice icon () appears at the top right-hand corner of the display.

[In]: The notice alerts you when your ship's speed is within the range set.

[Out]: The notice alerts you when your ship's speed is lower or higher than the range set.

5. Select [2 Speed].
6. Enter the minimum and maximum speeds with the numeric keys.
7. Move the cursor to [Enter] then press the **NU/ CU ENT** key.
8. Press the **MENU/ESC** key to close the main menu.

Input Speed	
Minimum	11.0 kn
Maximum	15.0 kn
Enter	Cancel

To turn off the ship speed notice, select [1 Off] at step 4.

6.5 Trip Notice

The trip notice alerts you when your ship's trip has travelled the distance specified.

1. Press the **MENU/ESC** key to open the main menu.
2. Select [4 Notice Setting] then [4 Trip].

Trip	
1	Status : Stop
2	Range

3. Select [2 Range].

Input distance	
1000.00	NM
Enter	Cancel

4. Enter the trip distance with the numeric keys.
5. Move the cursor to [Enter] then press the **NU/ CU ENT** key.
6. Select [1 Status] then [2 Start/Restart]. The trip notice icon () appears at the top right-hand corner of the display.
7. Press the **MENU/ESC** key to close the main menu.

To turn off the trip notice, select [1 Stop] at step 6.

6.6 DC Report (Satellite Report for Disaster and Crisis Management)

The DC report provides disaster and crisis management information such as earthquakes and tsunamis. There are 12 types of information below.

- Earthquake early warning
- Nankai trough earthquake
- Volcano
- Flood
- Hypocenter
- Tsunami
- Ash Fall
- Typhoon
- Seismic intensity
- Northwest Pacific tsunami
- Weather
- Marine

Note: The DC reports are displayed in Japanese.

To receive DC reports, the following settings are required:

MENU/ESC key - [8 System Setting] - [6 Beacon/SBAS] - [7 QZSS] - [2 Correction] - [1 Yes] (For details, see subsection 9.4.4.)//.

6.6.1 DC report log

Up to 100 reports are displayed on the DC report log screen. The newest report is displayed at the top.

1. Press the **MENU/ESC** key to open the main menu.
2. Select [4 Notice Setting] then [5 DC Report].

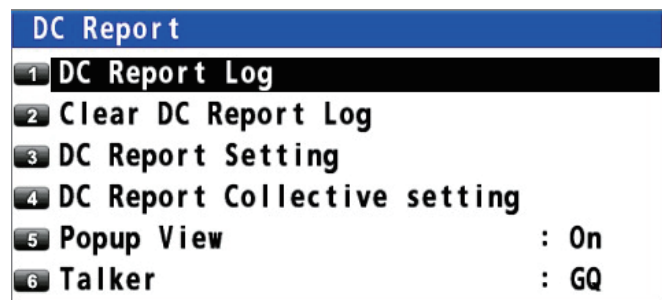

3. Select [1 DC Report Log].

DC Report Log			
001		【訓練】洪水情報(発表) 警報解除 鬼怒川(栃木県・茨城県)	12/19 06:30
002		震度情報(発表) 震度 5 弱 青森県	12/16 05:25
003		震源情報(発表) 青森県東方沖 マグニチュード : 5.5	12/16 05:25
004		【訓練】降灰情報(発表) 少量の降灰 熊本県高森町、熊本県南阿蘇村	12/12 14:50

DC report icon

Report contents

Date and time of occurrence

Scroll bar: Use the cursorpad (▼ or ▲) to display the hidden DC reports.

NUI/CU ENT Display detailed information
 NUI/CU ENT Hold Mark all as read
 ▲ ▼ Select an active item MENU ESC Close

Unread reports are displayed in black, and read reports are displayed in gray. To mark all reports as read, long-press the **NU/CU ENT** key.

6. NOTICES

- To display detailed information for DC report, use the cursorpad (▼ or ▲) to select the DC report then press the **NU/CU ENT** key.

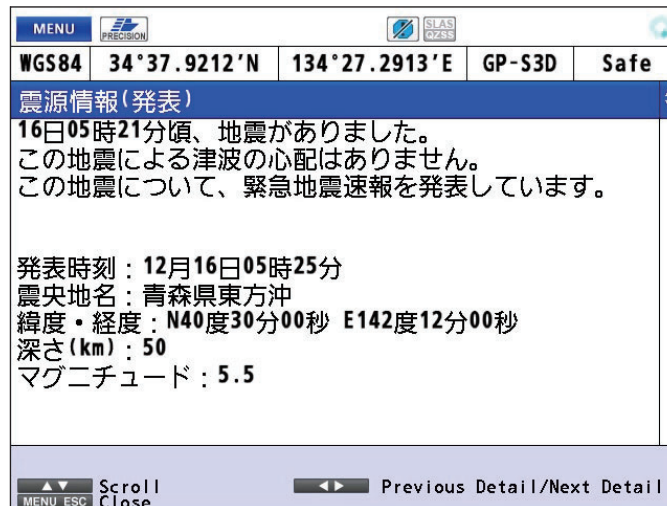

Use the cursorpad (◀) to display detailed information for the previous DC report, ▶ for the next DC report.

- Press the **MENU/ESC** key to return to the DC report log screen.
- Press the **MENU/ESC** key to close the DC report log.

6.6.2 How to clear the DC report log

- Press the **MENU/ESC** key to open the main menu.
- Select [4 Notice Setting] then [5 DC Report].
- Select [2 Clear DC Report Log]. The confirmation message appears.
- Select [1 Yes] to clear the DC report log.
- Press the **MENU/ESC** key to close the main menu.



6.6.3 How to set the DC report

There are four types of priority for DC report; maximum priority, priority, regular, training/test. You can individually set whether to display these four types of messages for 12 types of reports. These settings are applied to the DC report log screen (see subsection 6.6.1) and the popup (see subsection 6.6.4).

- Press the **MENU/ESC** key to open the main menu.
- Select [4 Notice Setting] then [5 DC Report].

3. Select [3 DC Report Setting].

MENU				
WGS84	35°07.7619'N	135°29.0050'E	GP-S3D	Safe
Disaster Category				
Earthquake	Hypocenter		Seismic Intensity	
Early Warning	Off		Off	
Nankai Trough Earthquake	Tsunami		Northwest Pacific Tsunami	
Off	Off		Off	
Volcano	Ash Fall		Weather	
Off	Off		Off	
Flood	Typhoon		Marine	
Off	Off		Off	
▲▼◀▶ Select an active Item MENU ESC Close				

4. Select the disaster category to change the settings then press the **NU/CU ENT** key.

Report Classification	
1	Maximum priority: On
2	Priority : On
3	Regular : On
4	Training/Test : On

5. Select [1 Maximum priority], [2 Priority], [3 Regular], or [4 Training/Test].
6. Select [1 Off] or [2 On].
7. Use the cursorpad (◀) to return to the [Disaster Category] screen. Repeat steps 4 to 6 to change settings for other disaster categories.
8. Press the **MENU/ESC** key to close the main menu.

1	Off
2	On

How to set DC report all at once

To set 12 types of DC report all at once, do the following:

- Press the **MENU/ESC** key to open the main menu.
- Select [4 Notice Setting] then [5 DC Report].
- Select [4 DC Report Collective setting].
- Select [1 Off] or [2 On]. The confirmation message appears.
- Select [1 Yes].
- Press the **MENU/ESC** key to close the main menu.

1	Off
2	On

Are you sure?	
1	Yes
2	No

6.6.4 Popup view

When a DC report occurs, a popup as shown below can be turned on or off on the screen.

Note: Only the popups with the highest priority during broadcasting are displayed.

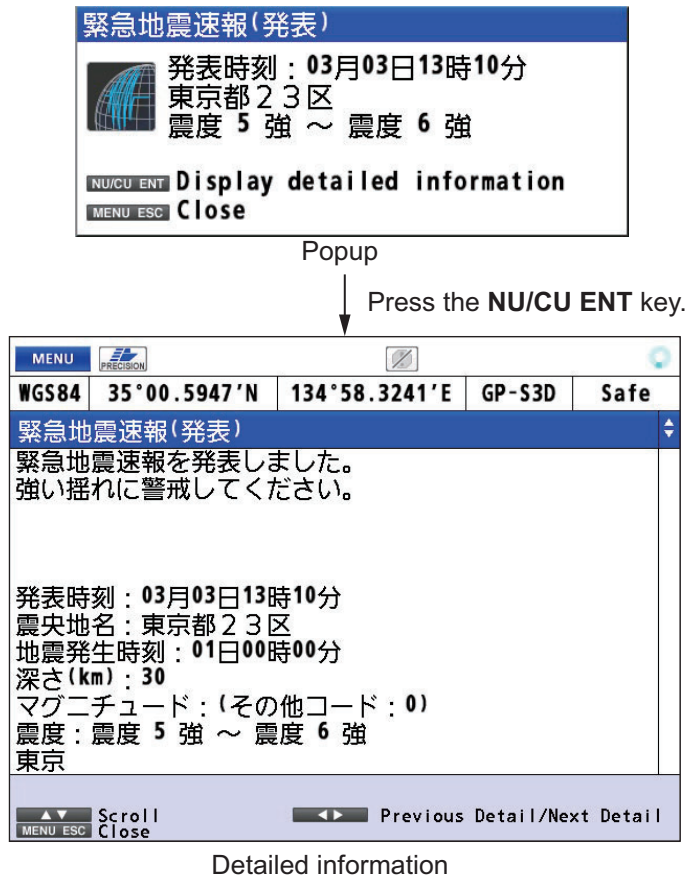

1. Press the **MENU/ESC** key to open the main menu.
2. Select [4 Notice Setting] then [5 DC Report].
3. Select [5 Popup View].
4. Select [1 On] to turn on the popup, [2 Off] to turn off the popup.
5. Press the **MENU/ESC** key to close the main menu.

6.6.5 How to set the talker for DC report

1. Press the **MENU/ESC** key to open the main menu.
2. Select [4 Notice Setting] then [5 DC Report].
3. Select [6 Talker].
4. Select [1 GQ] or [2 QZ].
 - [1 GQ]: Talker based on IEC-61162-1(2).Ed5
 - [2 QZ]: Talker based on IS-QZSS-DCR
5. Press the **MENU/ESC** key to close the main menu.



7. DISPLAYS

There are five display modes: PLOTTER, SAT VIEW, HIGHWAY, COURSE and DATA. This chapter describes the display modes except for PLOTTER.

7.1 Sat view Display

The sat view display provides information about GPS/GLONASS satellite position, DGPS/DGLONASS beacon station information and signal quality. There are four sat view displays: GNSS, beacon, graph for signal noise ratio and graph for satellite angle.

Use the cursorpad (\blacktriangle or \blacktriangledown) to change the displays, in the following sequence.

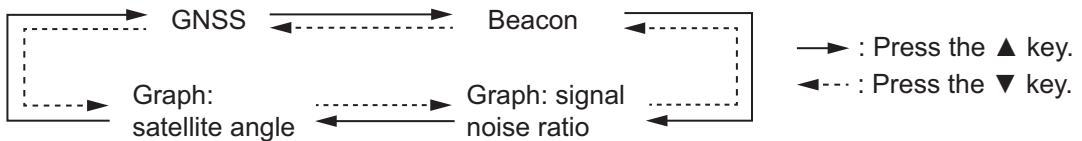

GNSS

The GNSS display shows the condition of satellite positioning system. Number, azimuth and elevation angle of all satellites (if applicable) in view of your receiver appear.

Use the cursorpad (\blacktriangleleft or \blacktriangleright) to change the satellite positioning system in the following sequence.



The following illustration is an example sat view display for GPS.

Satellites used for positioning (Satellite numbers used for positioning are displayed in white, or black if not used for positioning.)
 QZSS L1S satellites (numbered in the 180 series) are not displayed, however, their signal level appears on the screen.

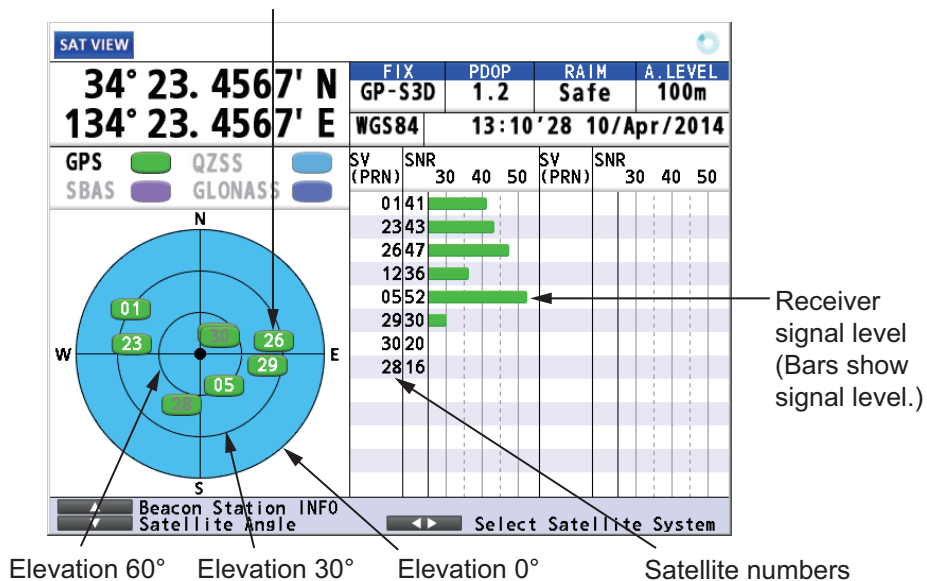

Elevation

The area set on [Elevation Mask] is displayed in white. See "Satellite elevation" on page 9-5 for how to set elevation mask.

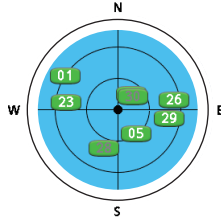

Elevation mask is set to 10°

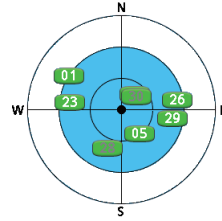

Elevation mask is set to 30°

Beacon

The beacon display shows the DGPS/DGLONASS beacon station information.

BEACON				
34° 23. 4567' N	FIX	PDOP	RAIM	A. LEVEL
134° 23. 4567' E	GP-S3D	1.2	Safe	100m
WGS84 12:11'29 10/Apr/2014				
Receive		Next 1	Next 2	
Update Time : UTC 11:30 10/Apr/2014				
Receiver Type : Internal (AUTO)				
Station Name : E_Saki				
ID REF1/REF2 : 0696/0697				
Frequency : 320.5kHz				
Distance : 19NM				
Station Health : OK				
Signal Quality SN : 35dB				
WER: 0% SS : 57dB				
▲ Signal Noise Ratio		NU/CU ENT		More Information
▼ Receiver Signal Level		◀ ▶		Select Beacon Station

← Press the ◀ or ▶ key to select [Next 1]* or [Next 2]*.
*: w/internal beacon receiver

[Receive]: Station used for positioning (the nearest station)
[Next 1]: Second nearest station
[Next 2]: Third nearest station

Beacon station information

Press the NU/CU ENT key.

BEACON				
34° 23. 4567' N	FIX	PDOP	RAIM	A. LEVEL
134° 23. 4567' E	GP-S3D	1.2	Safe	100m
WGS84 12:11'40 10/Apr/2014				
Station Information				
Station Name : E_Saki				
Station ID : 0648				
ID REF1/REF2 : 0696/0697				
Frequency : 320.5kHz				
Position : 34°35'N 135°59'E				
Datum : WGS84				
Operation Status : Operational				
Bit Rate : 200bps				
Distance : 19NM				
▲ Signal Noise Ratio		NU/CU ENT		More Information
▼ Receiver Signal Level		◀ ▶		Select Beacon Station

When [Beacon Station] is set to [Set Parameter], the information of manually selected station is displayed in [Receive]. If the station of [Receive] is equal to [Next 1] or [Next 2],
- When [Receive] = [Next 1],
[Next 1]: Second nearest station
[Next 2]: Third nearest station
- When [Receive] = [Next 2],
[Next 1]: First nearest station
[Next 2]: Third nearest station
- Others,
[Next 1]: First nearest station
[Next 2]: Second nearest station

Detailed beacon station information

Press the NU/CU ENT key.

BEACON				
34° 23. 4567' N	FIX	PDOP	RAIM	A. LEVEL
134° 23. 4567' E	GP-S3D	1.2	Safe	100m
WGS84 12:13'26 10/Apr/2014				
Beacon Text Message				
0025,WeatherStation,N.1m,1015hpa,Wave13m,				
▲ Signal Noise Ratio		NU/CU ENT		More Information
▼ Receiver Signal Level		◀ ▶		Select Beacon Station

Type16 message is displayed with alphanumeric characters and symbols.
Type36 message is displayed with alphanumeric characters, symbols, and Cyrillic alphabets.

Type16/Type36 message

Press the NU/CU ENT key.

Graph

The graph displays show signal to noise ratio and satellite angle used for positioning for the last six hours.

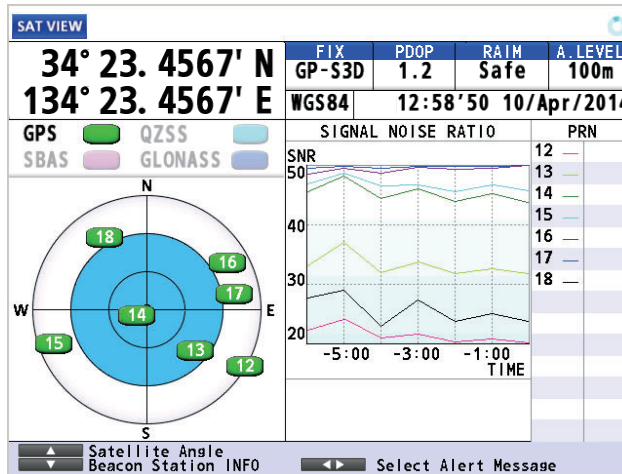

Signal to noise ratio

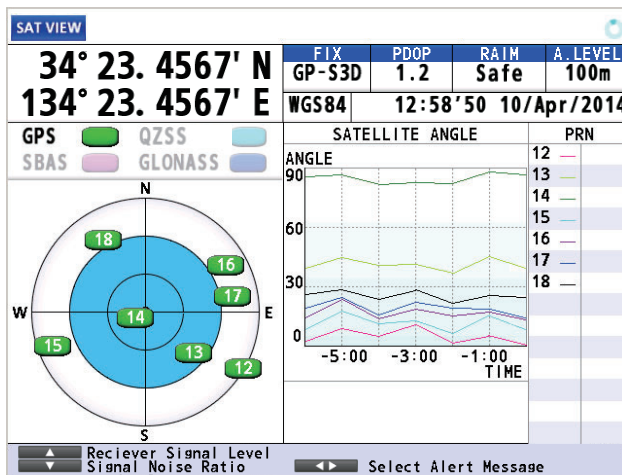

Satellite angle

An alert (see chapter 8), which informs you to various types of errors, may appear on a graph display, with a gray bar and triangle. Below is an example of an alert on the signal noise ratio graph.

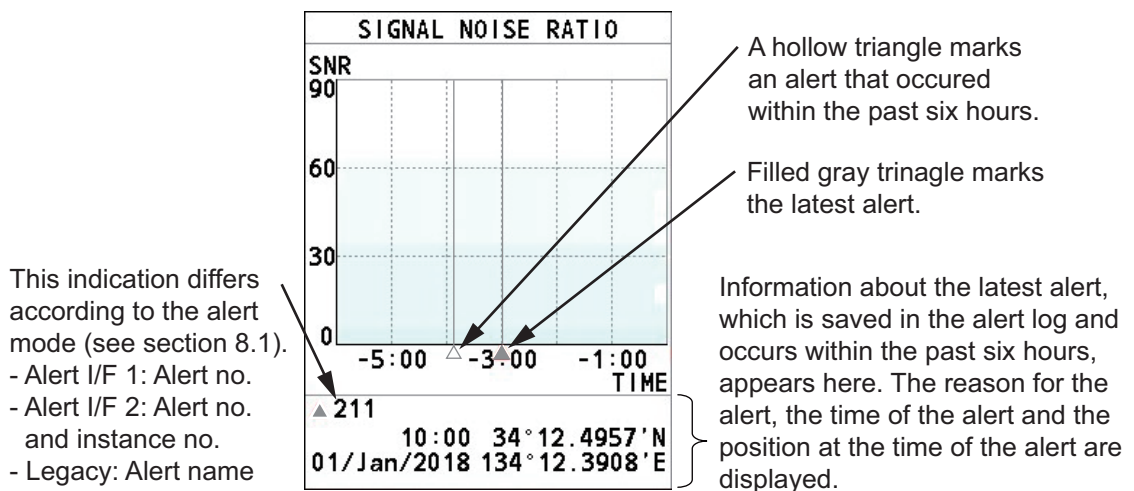

7.2 Highway Display

The highway display provides a 3-D view of own ship's progress toward destination.

Use the cursorpad (◀ or ▶) to change the data at the right-hand of the display.

The Highway Display interface consists of several sections:

- FIX Data:**

FIX	PDOP	RAIM	A. LEVEL
GP-S3D	1.2	Safe	100m
WGS84	12:19'45 10/Apr/2014		
- Navigation Data:**

COG	077.6°
SOG	12.0kn
NAVIGATION	
WPT ID:	0053
NAME:	P0TNT0053
RANGE:	1.05NM
ETA:	15:30'04
TTG:	04day 05:23
- Weather Data:**

WIND DIR:	123.0°
WIND SPD:	30.4m/s
- Station Data:**

STATION 1	
NAME:	akap
35°49.6508'N	136°31.8592'E
TIME:	15:59
10/Apr/2014	
STATION 2	
NAME:	TTTTT
36°52.1234'N	136°52.1234'E
TIME:	18:45
10/Apr/2014	
WIND DIR:	128.5°
WIND SPD:	35.8m/s
- Attitude Data:**

ATTITUDE	
ROLL	→ 89.0°
PITCH	↓ 34.5°
HEAVE	0.1m

Navigation controls and indicators:

- North mark (indicated by a red arrow pointing up)
- Waypoint (indicated by a red circle with '0053')
- Weather data (wind direction and speed) (See paragraph 2.1.14.)
- Attitude gauge (See page 9-3.)

Navigation instructions:

- ↓ : Press the ▶ key.
- ↑ : Press the ◀ key.

Additional information:

- When weather data is received from the beacon station.
- When the data for roll, pitch or heave is received.

ROLL and PITCH indicators:

- : Starboard
- ←: Port
- ↑: Bow rising angle
- ↓: Bow falling angle

7.3 Course Display

The course display shows the course information. The information at the right-hand side of the display is different between autopilot connection and no autopilot connection.

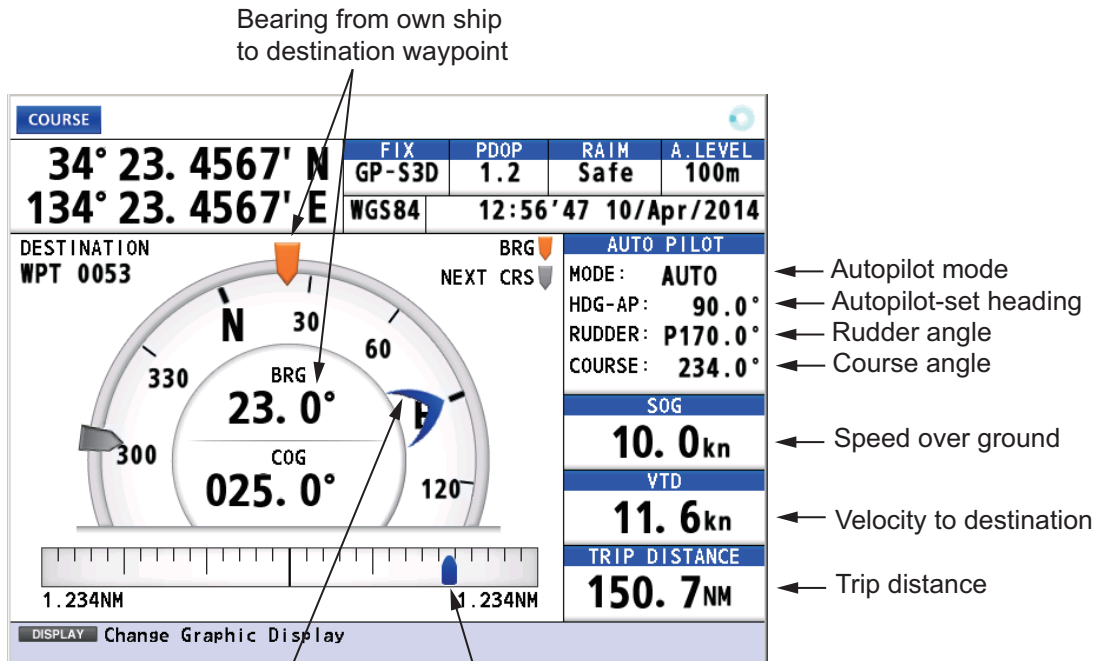

Heading (for autopilot) Cross track distance indication
With autopilot connection

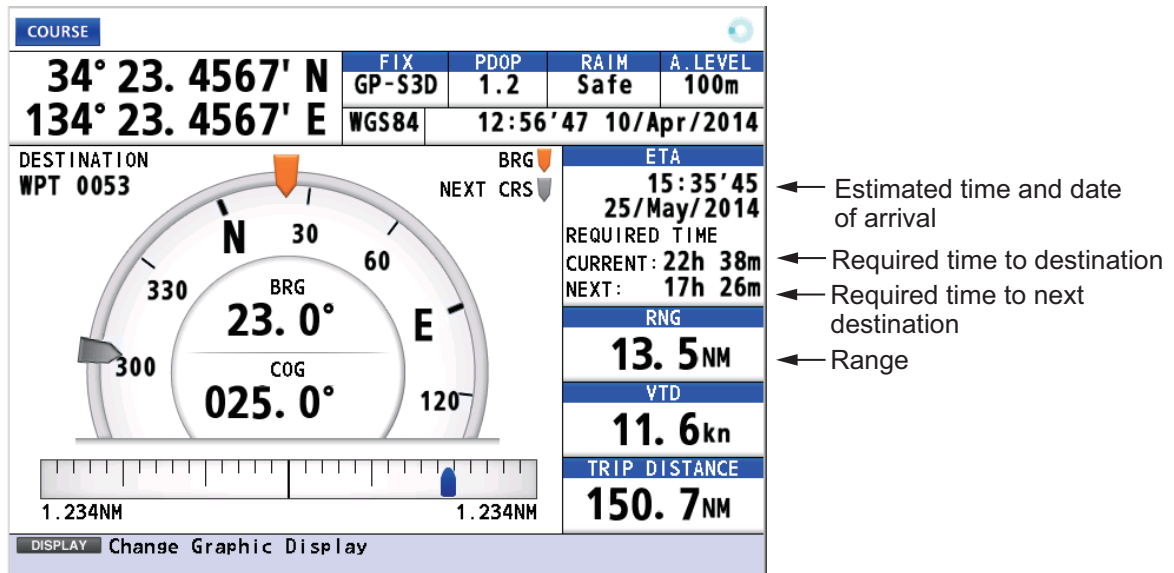

No autopilot connection

7.4 Data Display

The data display shows the navigation data. Use the cursorpad (◀ or ▶) to change the data to display.

The image shows two screenshots of the 'DATA' display screen. The top screenshot displays the following data:

FIX	PDOP	RAIM	A. LEVEL
GP-S3D	1.2	Safe	100m

Own ship's position* → WGS84 **34°23.4567'N**
134°23.4567'E

Speed over ground → SOG: **13.4 kn**

Range → RNG: **31.23 NM**

Heading → HDG: **123.4°**

Course over ground → COG: **123.4°**

NAVIGATION: Destination WPT NO.0056 POINT0056
 Next WPT WPT NO.0057 POINT0057

TIME AND DATE: UTC 13:57'47 10/Apr/2014
 POSN FIX: 13:57'47 10/Apr/2014

Press the ◀ or ▶ key.

The bottom screenshot displays the following data:

ETA	Route Distance	NAVIGATION
18:10'23	123.4 NM	Destination WPT NO.0056 POINT0056
ETA/ETA(Plan) 18:10'23	TTG 01day 04:12	Next WPT WPT NO.0057 POINT0057

Own ship's position* → WGS84 **34°23.4567'N**
134°23.4567'E

Route total distance → **123.4 NM**

Estimated time of arrival at the final destination → 18:10'23

Estimated time of arrival and planned estimated time of arrival at destination → 18:10'23

Time to go to destination → 01day 04:12

*: Shows the ship's position adjusted with the setting position offset based on the selected datum (refer to paragraph 9.3.5).

** : For Russian mode, the UTC icon is not displayed when there is no positioning data.

How to customize the display

You can arrange the data to display and show the data in the order desired. Availability of data depends on the sensors connected.

1. Press the **MENU/ESC** key to open the main menu.
2. Select [8 System Setting], then [2 Plotter].

3. Select [4 User Defined].

User Defined	
1	Custom 1 : RNG
2	Custom 2 : SOG
3	Custom 3 : HDG
4	Custom 4 : COG
5	Custom 5 : ETA
6	Custom 6 : Route Distance
7	Custom 7 : ETA/ETA(Plan)
8	Custom 8 : TTG

4. Select [1 Custom 1].

1	SOG
2	COG
3	RNG
4	BRG
5	SST
6	DPT
7	XTD
8	Average COG
9	Average SOG
0	TTG
	ETA

- [TTG]: Time to go to destination
- [TRIP]: Distance to go to destination
- [TRIP TIME]: Time elapsed since the destination was set
- [Route TTG]: Time to go to the final destination
- [VTD]: Velocity to destination
- [ETA/ETA(Plan)]: ETA is estimated time of arrival at destination. ETA(Plan) is planned estimated time of arrival at destination.

5. Select an option.

6. Repeat steps 4 and 5 to select options for [2 Custom 2] to [8 Custom 8].

7. Press the **MENU/ESC** key to close the main menu.

DATA			
FIX	PDOP	RAIM	A. LEVEL
GP-S3D	1.2	Safe	100m
WGS84	34°23.4567'N		TIME AND DATE
	134°23.4567'E		UTC 13:57'47 10/Apr/2014
			POSN FIX 13:57'47 10/Apr/2014
RNG	SOG	NAVIGATION	
31.23 NM	13.4 kn	Destination	
		WPT NO.0056 POINT0056	
HDG	COG	Next WPT	
123.4°	123.4°	WPT NO.0057 POINT0057	
Change Data to Display Select Box to Zoom in			

DATA			
FIX	PDOP	RAIM	A. LEVEL
GP-S3D	1.2	Safe	100m
WGS84	34°23.4567'N		TIME AND DATE
	134°23.4567'E		UTC 13:57'47 10/Apr/2014
			POSN FIX 13:57'47 10/Apr/2014
ETA	Route Distance	NAVIGATION	
18:10'23	123.4 NM	Destination	
		WPT NO.0056 POINT0056	
ETA/ETA(Plan)	TTG	Next WPT	
18:10'23 18:23'04	01day 04:12	WPT NO.0057 POINT0057	
Change Data to Display Select Box to Zoom in			

Press the ◀ or ▶ key.

Custom 1	Custom 2
Custom 3	Custom 4

Custom 5	Custom 6
Custom 7	Custom 8

How to zoom information

1. Press the **CURSOR ON/OFF** key. An information is highlighted as follows.

An information highlighted →

DATA			
FIX	PDOP	RAIM	A. LEVEL
GP-S3D	1.2	Safe	100m
WGS84	34°23.4567'N		TIME AND DATE
	134°23.4567'E		UTC 13:57'47 10/Apr/2014
			POSN FIX 13:57'47 10/Apr/2014
RNG	SOG	NAVIGATION	
31.23 NM	13.4 kn	Destination WPT NO.0056 POINT0056	
HDG	COG	Next WPT WPT NO.0057 POINT0057	
123.4°	123.4°		
▲▼ Select Data Box to Zoom in ZOOM IN Zoom in CURSOR ON/OFF Deselect			

2. Use the cursorpad (▲ or ▼) to select the information to zoom in. SOG is highlighted in the following example.

DATA			
FIX	PDOP	RAIM	A. LEVEL
GP-S3D	1.2	Safe	100m
WGS84	34°23.4567'N		TIME AND DATE
	134°23.4567'E		UTC 13:57'47 10/Apr/2014
			POSN FIX 13:57'47 10/Apr/2014
RNG	SOG	NAVIGATION	
31.23 NM	13.4 kn	Destination WPT NO.0056 POINT0056	
HDG	COG	Next WPT WPT NO.0057 POINT0057	
123.4°	123.4°		
▲▼ Select Data Box to Zoom in ZOOM IN Zoom in CURSOR ON/OFF Deselect			

3. Press the **ZOOM IN** key to zoom in the SOG information.

DATA			
FIX	PDOP	RAIM	A. LEVEL
GP-S3D	1.2	Safe	100m
SOG			
13.4 kn			
ZOOM OUT Zoom Out			

To go to the original display, press the **ZOOM OUT** key.

4. Press the **CURSOR ON/OFF** key to deselect the SOG information.

7.5 LORAN Settings

7.5.1 How to display LORAN on the data screen

LORAN A and LORAN C can be displayed on the data screen as follows.

1. Press the **MENU/ESC** key to open the main menu.
2. Select [8 System Setting], then [2 Plotter].
3. Select [4 User Defined].
4. Select from [1 Custom 1] to [8 Custom 8] as appropriate (see "How to customize the display" on page 7-6).
5. Select [LORAN A] or [LORAN C] at the end of the option list.

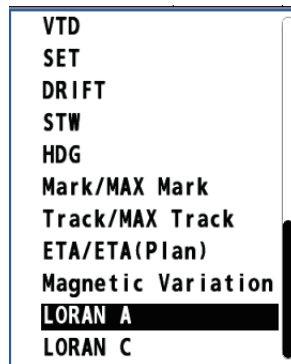

6. Press the **MENU/ESC** key to close the main menu.

7.5.2 How to adjust LORAN station settings

You can adjust the LORAN station and time offset value as follows.

1. Press the **MENU/ESC** key to open the main menu.
2. Select [8 System Setting], then [2 Plotter].
3. Select [5 LORAN], then select [LORAN A] or [LORAN C] as appropriate. Below setting window is shown.

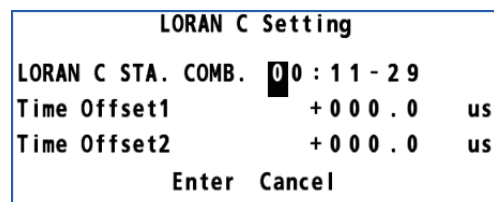
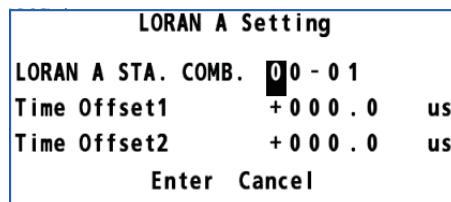

4. Set the LORAN station code number and time offset.
 - Station codes for LORAN A: from 00 to 22
 - Station codes for LORAN C: from 00 to 30
5. Select [Enter] to set the settings.
6. Press the **MENU/ESC** key to close the main menu.

This page is intentionally left blank.

8. ALERTS

“Alert” is a generic name for a notice to any unusual or potentially dangerous situation generated within the system. There are two types of alerts, warning and caution.

Warning: Conditions or situations which require immediate attention for precautionary reasons. **Caution:** Awareness of a condition which continues to require attention out of the ordinary consideration of the situation.

8.1 Overview

The GP-170 has the alerts according to the alert mode Alert I/F 1, Alert I/F 2 or Legacy as follows. The alert mode is set at installation. For full lists of the alerts for each alert mode, see "ALERT LIST" on page AP-16.

Alert I/F 2

No.	Inst.	Alert description text	Priority
3056	0	HDOP exceeded.	Caution/B
3008	1	GNSS core fault.	Warning/B
	2	Too few tracking Satellites.	
	3	Antenna short-circuited.	
	4	First fix fault	
3055	0	Loss of differential signal.	• Russian mode: Warning/B • Others: Caution/B
3012	0	Beacon Status Unhealthy	
401903	0	Check the audit log	Caution/B
401906	0	Check other devices in the network	Caution/B

Note 1: "Inst." denotes "Instance number" for the alert.

Note 2: When a warning is not acknowledged within four minutes fifty seconds, the warning is repeated.

Alert I/F 1, Legacy

No.	Alert description text	Priority
009	Antenna short-circuited.	Warning/B

8. ALERTS

No.	Alert description text	Priority
010	<ul style="list-style-type: none"> • D3D turned to 3D. • D3D turned to 2D. • D2D turned to 3D. • D2D turned to 2D. • S3D turned to 3D. • S3D turned to 2D. • S2D turned to 3D. • S2D turned to 2D. • Q3D turned to 3D. • Q3D turned to 2D. • Q2D turned to 3D. • Q2D turned to 2D. • D3D turned to "No Fix". • D2D turned to "No Fix". • S3D turned to "No Fix". • S2D turned to "No Fix". • Q3D turned to "No Fix". • Q2D turned to "No Fix". 	Caution/B
210*	HDOP exceeded.	Caution/B
211	No calculation of position.	Warning/B
212	Loss of position.	Warning/B
213	Loss of differential signal.	Caution/B
215	Differential integrity status.	Caution/B

*: Own ship's position is updated even when HDOP is exceeded.

Note: When a warning is not acknowledged within three minutes, the warning is repeated.

When an alert condition occurs, the buzzer sounds (except for a caution), and the number of alert and the alert message appear at the bottom of the display. The examples in the figures below are for Alert I/F 1.

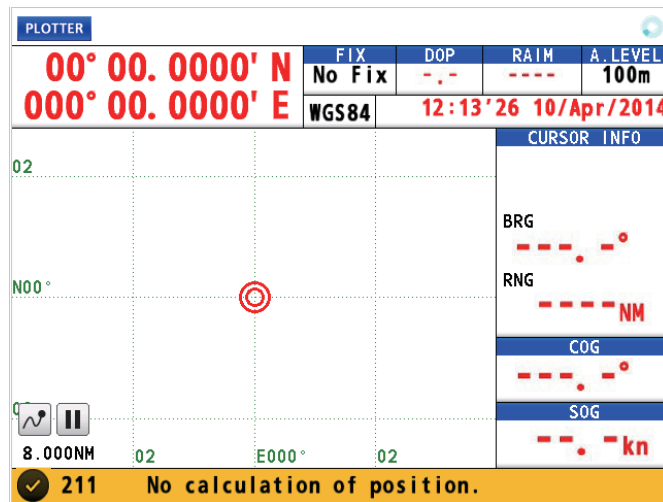

Example 1: Warning

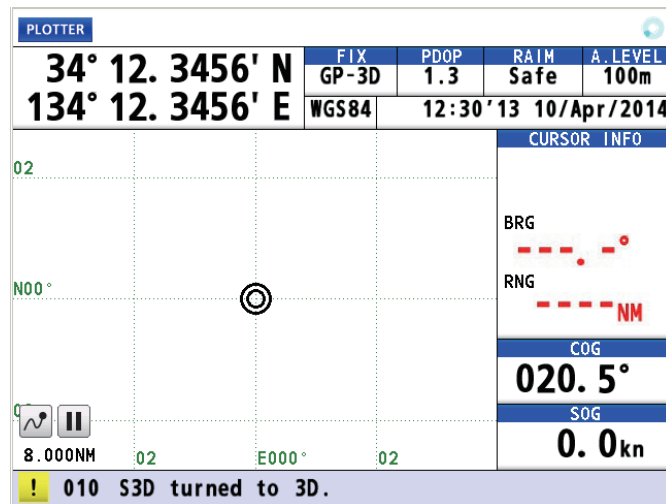

Example 2: Caution

Alert category

Priority	Icon	Visual indication
Warning	Circle	<ul style="list-style-type: none"> Acknowledged: Yellow-orange Not acknowledged: Yellow-orange, flashing
Caution	Square	Yellow

For details, see page AP-8.

Multiple alerts

When multiple alerts occur, the icons and the number of alerts currently occurred appear at the bottom right of the display. The examples in the figures below are for Alert I/F 1.

8. ALERTS

- When two alerts for caution occur:

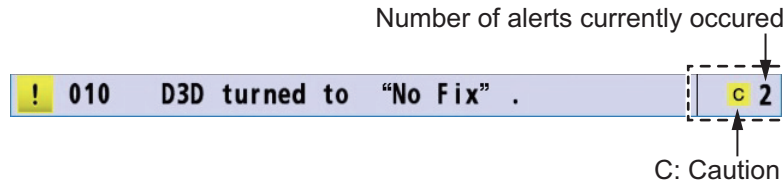

- When two alerts for warning occur:

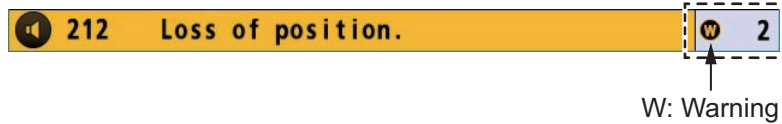

- When three alerts (one for warning and two for caution) occur:

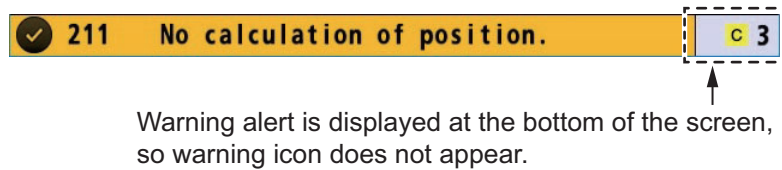

- When four alerts (two for warning and two for caution) occur:

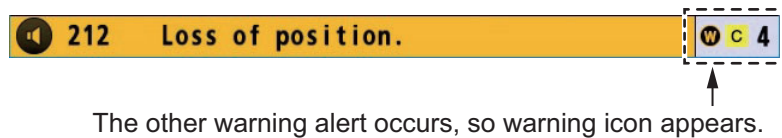

Background alerts

A background alert is an alert that is occurring simultaneously with the displayed alert message. For example, if there are two alerts of the same priority, the alert number and name of the first-occurring alert is displayed, and the second alert is indicated with an icon corresponding to the alert priority. Warning background alerts have the "W" icon; caution background alerts have the "C" icon.

8.2 Alert List

The alert list shows all currently violated alerts and state of acknowledgment. All unacknowledged alerts are shown, even those whose reason for alert has passed (except for a caution). To open the alert list, long-press the **MENU/ESC** key. To open the alert list from the menu, do the following:

1. Press the **MENU/ESC** key to open the main menu.
2. Select [5 Alert] then [1 Active Alert] to show the alert list. Unacknowledged alerts flash (except for a caution).

Title bar

WGS84 35°45.6789'N 135°45.6789'E GP-S3D Safe

Active Alert

009 Antenna short-curcued
15:10 10/Apr/2014 35° 45.6789'N 135° 45.6789'E

212 Loss of position
15:06 10/Apr/2014 35° 05.4567'N 135° 17.4567'E

211 No calculation of position
14:45 10/Apr/2014 34° 67.1234'N 134° 56.1234'E

210 HDOP exceeded
14:20 10/Apr/2014 33° 45.2345' 133° 67.2345'

215 Beacon status unhealthy
14:03 10/Apr/2014 32° 89.3456'N 132° 45.3456'E

213 Loss of differential signal
13:50 10/Apr/2014 35° 45.6789'N 135° 45.6789'E

009 Antenna short-curcued.

Not acknowledged

WGS84 35°45.6789'N 135°45.6789'E GP-S3D Safe

Active Alert

215 Beacon status unhealthy
14:03 10/Apr/2014 35° 45.6789'N 135° 45.6789'E

213 Loss of differential signal
13:50 10/Apr/2014 35° 45.6789'N 135° 45.6789'E

Acknowledged

Alert number → Alert name →

Alert icon →

213 Loss of differential signal
13:50 10/Apr/2014 35° 45.6789'N 135° 45.6789'E

Date and time of occurrence → Position of occurrence

When there are no alerts, "No Active Alerts" is displayed at the right of the title bar.

3. Press the **MENU/ESC** key to close the alert list.

8.3 Alert Log

The alert log shows the latest 50 alerts. When the log becomes full, the oldest entry is erased to make room for current alerts.

1. Press the **MENU/ESC** key to open the main menu.
2. Select [5 Alert] then [4 Alert Log] to show the alert log.

MENU

WGS84 35°45.6789'N 135°45.6789'E GP-S3D Safe

Alert Log

Warning

01 009 Antenna short-curcued
15:10 10/Apr/2014 35° 45.6789'N 135° 45.6789'E
ACK : 15:14 10/Apr/2014|RECT: 15:20 10/Apr/2014

Caution

02 215 Beacon status unhealthy
14:03 10/Apr/2014 35° 45.6789'N 135° 45.6789'E
ACK : 14:05 10/Apr/2014|RECT: 14:08 10/Apr/2014

Caution

03 213 Loss of differential signal
13:50 10/Apr/2014 35° 45.6789'N 135° 45.6789'E
ACK : 13:55 10/Apr/2014|RECT: 13:40 10/Apr/2014

215 Beacon status unhealthy

Priority

Alert number → Alert name →

Caution

03 213 Loss of differential signal
13:50 10/Apr/2014 35° 45.6789'E
ACK : 13:55 10/Apr/2014|RECT: 13:40 10/Apr/2014

Date and time of occurrence → Date and time of acknowledgement → Date and time when occurrence factor is gone → Position of occurrence →

List no.

3. Press the **MENU/ESC** key to close the alert log.

8.4 How to Acknowledge Alerts

With the ACK/DELETE key

When an alert condition occurs, the buzzer sounds (except for a caution) and the name of the alert appears at the bottom of the display. Press the **ACK/DELETE** key to acknowledge the alert. The buzzer stops for a warning. If multiple alerts are violated, a high-priority alert is acknowledged in order.

How to acknowledge an alert from the alert list

1. Open the alert list (see section 8.2).
2. Use the cursorpad (▲ or ▼) to select the alert to acknowledge then press the **NU/ CU ENT** key.

8.5 How to Silence Alerts

When connected to the same network, alerts output by this equipment can be silenced remotely. Refer to the related equipment’s manual for how to silence an alert at that equipment.

Note: The buzzer sounds again if the alert condition is not rectified or the alert is not acknowledged within 30 seconds.

8.6 Responsibility Transfer Alert

MSC302(87) requires the use of the “responsibility transfer alert,” which functions in multiple sensor, multiple equipment installations. When one sensor or one equipment fails but does not disturb the system operation (other sensor or equipment is normal), the CAM automatically sends the “responsibility transfer alert” (ACN sentence) to the sensor or equipment that generated the alert.

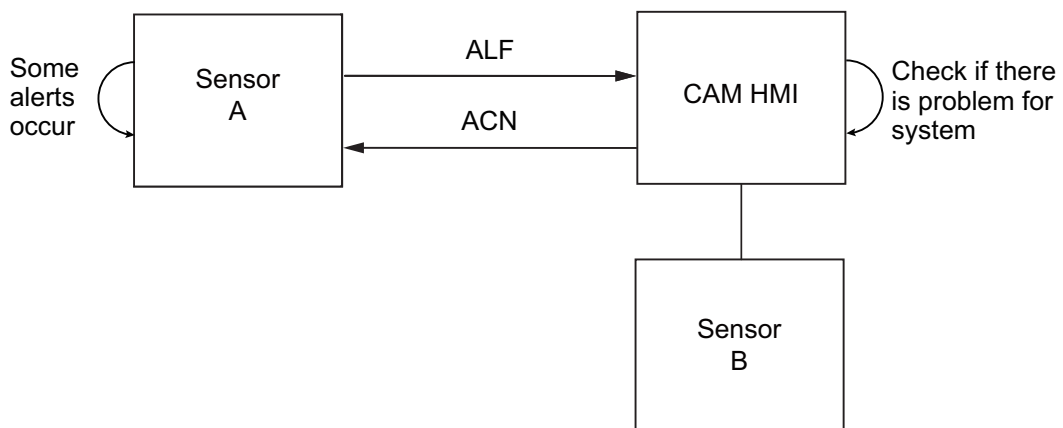

If the sensor or equipment refuses the responsibility transfer, normal operation is restored.

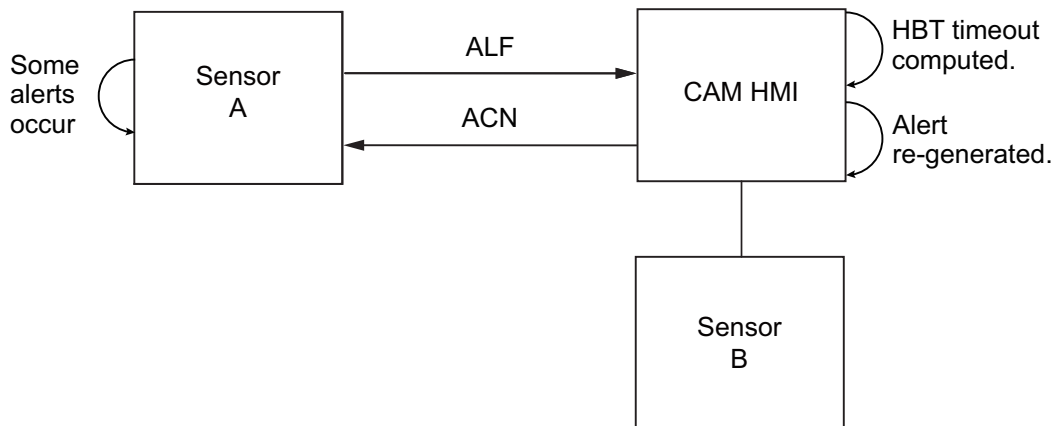

If the HBT sentence is not received within the prescribed time interval, the alert processed as responsibility transfer alert is made active.

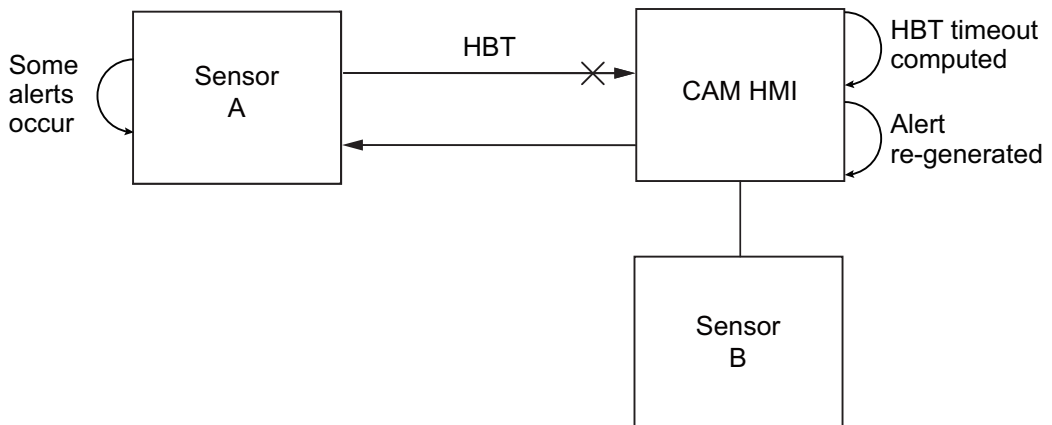

8.7 Alert Continuation

Active alerts are terminated and their status is changed to "normal" under the following example circumstances.

- When [1 Method] in [5 GNSS] of the [8 System Setting] menu is changed.
- When [2 Mode] in the [5 Alert] menu is changed.
- When [8 Demo] in the [8 System Setting] menu is activated/deactivated.

8.8 UTC De-synchronization and Alert Output

For vessels assigned as [Russia] at installation, the time/date field of some alerts sentences may be output as "null" under the following circumstances.

- The system is starting up.
- The system is unable to obtain a position fix.

8. ALERTS

This page is intentionally left blank.

9. OTHER FUNCTIONS

This chapter describes menu items not described in other chapters.

9.1 Unit Setup Menu

You can set the units of measurement for distance, depth and water temperature.

1. Press the **MENU/ESC** key to open the main menu.
2. Select [8 System Setting] then [3 Unit Setup].

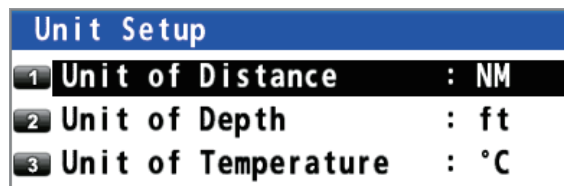

3. **Distance:** Select [1 Unit of Distance].
Depth: Select [2 Unit of Depth].
Water temperature: Select [3 Unit of Temperature].



Distance



Depth

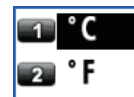

Water temperature

4. Select the unit.
5. Press the **MENU/ESC** key to close the main menu.

Note: When changing the units of measurement, the setting values for the notice setting can exceed the setting range. Reset the values (see subsection 4.1.1 and chapter 6).

9.2 Correction, Offset Menu

Position offset

You may apply an offset to the position to further refine its accuracy.

1. Press the **MENU/ESC** key to open the main menu.
2. Select [8 System Setting] then [4 Correction, Offset].

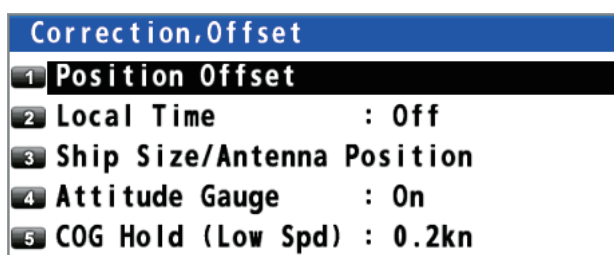

9. OTHER FUNCTIONS

3. Select [1 Position Offset].

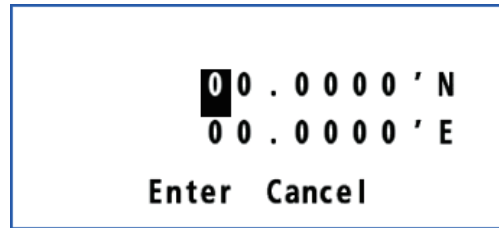

4. Enter the offset value with the numeric keys. Mark your ship's position on the chart to calculate the error with latitude and longitude, and enter the values. To change the coordinate, select "N" or "E" then press one of keys from **0** to **9**.
5. Move the cursor to [Enter] then press the **NU/CU ENT** key.
6. Press the **MENU/ESC** key to close the main menu.

Note: When you set the position offset, the Datum indication changes to 999 (User Defined).

Time difference

You can display time in UTC or local. For local time, enter the time difference between local time and UTC.

1. Press the **MENU/ESC** key to open the main menu.
2. Select [8 System Setting] then [4 Correction, Offset].
3. Select [2 Local Time].
4. Select [1 Off] or [2 Manual Input].
 [Off]: Uses UTC (Universal Time Coordinated). Go to step 7.
 [Manual Input]: Sets the time manually. Go to step 5.
5. Enter the difference time with the numeric keys. (If necessary, switch + and - with pressing one of keys from **0** to **9**.)
6. Move the cursor to [Enter] then press the **NU/CU ENT** key.
7. Press the **MENU/ESC** key to close the main menu.

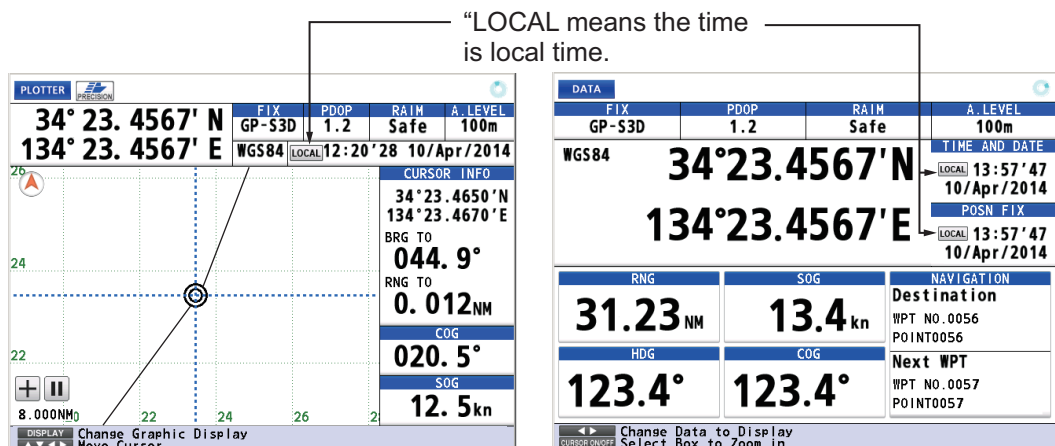
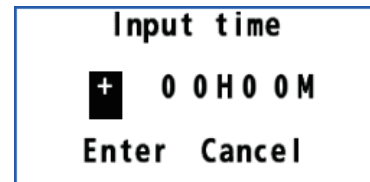

Ship size and antenna position

1. Press the **MENU/ESC** key to open the main menu.
2. Select [8 System Setting] then [4 Correction, Offset].
3. Select [3 Ship Size/Antenna Position].

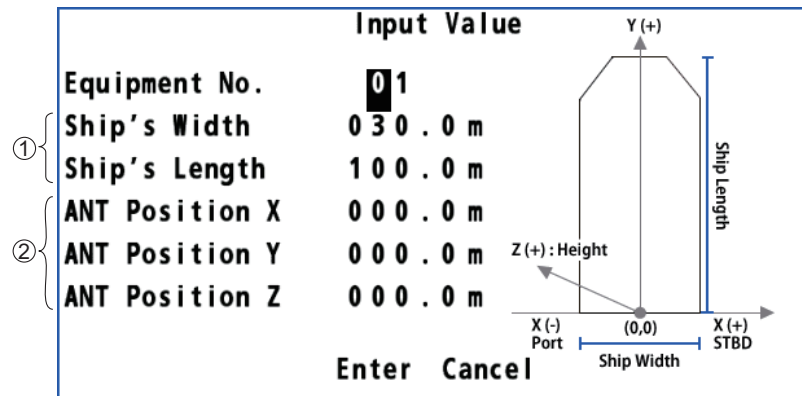

- ①: Set the width and length of your ship. Enter the values as correct as possible because these values influence the output sentence "POS". Note that these values are the upper limits for the values of ②.
 - ②: Set the mounting location for the antenna unit.
 X: The horizontal distance from the reference position "0" to the antenna position.
 Y: The forward distance from the reference position "0" to the antenna position.
 Z: The height from the summer load line to the antenna unit.
4. Enter the value for each item with the numeric keys. Refer to the figure at the right-hand of the display.
 5. Move the cursor to [Enter] then press the **NU/CU ENT** key.
 6. Press the **MENU/ESC** key to close the main menu.

Attitude gauge

The attitude gauge is displayed when the data for roll, pitch or heave is received.

1. Press the **MENU/ESC** key to open the main menu.
2. Select [8 System Setting], then [4 Correction, Offset].
3. Select [4 Attitude Gauge].



4. Select [1 On] or [2 Off].

[On]: Displays the attitude gauge (see the illustration in "Highway Display" on page 1-7) instead of the ship's icon on the highway display. When the data for roll, pitch or heave is not received, the ship's icon is displayed.
 [Off]: Hides the attitude gauge on the highway display.

5. Press the **MENU/ESC** key to close the main menu.

COG Hold (at low speeds)

To hold the same course at low speeds, do the following.

1. Press the **MENU/ESC** key to open the main menu.
2. Select [8 System Setting], then [5 COG Hold (Low Spd)].
3. Select 1.1 kn, 0.2 kn (set as factory default), or off as appropriate.
 [1.1 kn]: COG is not updated when speed is under 1.1 kn.
 [0.2 kn]: COG is not updated when speed is under 0.2 kn.
 [Off]: COG is updated regardless of ship's speed.
4. Press the **MENU/ESC** key to close the main menu.

9.3 GNSS Menu

9.3.1 How to select the positioning system

1. Press the **MENU/ESC** key to open the main menu.
2. Select [8 System Setting] then [5 GNSS].

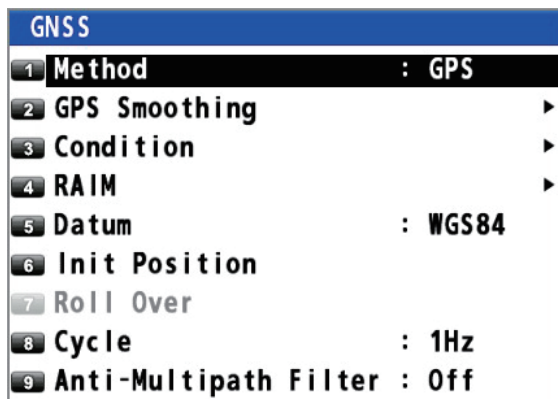

3. Select [1 Method].
4. Select [1 GPS], [2 GLONASS], or [4 Multi]. A confirmation message appears.



Changing this setting will restart the system in order to change the satellite system in use. Resumes GGA sentence output according to the settings.

Are you sure you want to change this setting?
 Yes No

For [1 GPS]

Changing this setting will restart the system in order to change the satellite system in use. Stops GGA sentence output. The following menu items will also change automatically.

[GNSS]-[RAIM]-[setting]:Changes to [Off]
 [Beacon/SBAS]-[Mode]:Changes to [GNSS]

Are you sure you want to change this setting?
 Yes No

For [4 Multi]

Changing this setting will restart the system in order to change the satellite system in use. Stops GGA sentence output. The following menu items will also change automatically.

[GNSS]-[Cycle]:Changes to [1Hz]
 [GNSS]-[RAIM]-[setting]:Changes to [Off]
 [Beacon/SBAS]-[QZSS]-[Positioning]:Changes to [No]
 [Beacon/SBAS]-[QZSS]-[Correction]:Changes to [No]

Yes No

For [2 GLONASS]



CAUTION

Because the GNSS signal is distributed to many devices, check in advance if all connected devices that receive the GNSS signal can receive the GNS/GLL sentences, before selecting the positioning method.

When selecting [2 GLONASS] or [4 Multi], the GGA sentence is not output and only the GNS/GLL sentences are output. The GNS/GLL sentences may not be received depending on the receiving device. When an error (alert, ship's position lost, etc.) occurs from the receiving device after changing the positioning method, immediately reset [1 Method] menu to [1 GPS].

5. Select [1 Yes]. The GP-170 restarts.

9.3.2 How to set the time for smoothing of position, speed and speed average

Position smoothing: When the receiving condition is unfavorable, the GPS/GLONASS fix may change randomly, even if the ship is dead in water. This change can be reduced by smoothing the raw GPS/GLONASS fixes. The higher the setting the more smoothed the raw data, however too high a setting slows response time to change in latitude and longitude. This is especially noticeable at high ship's speeds. Increase the setting if the GPS/GLONASS fix changes randomly.

Speed smoothing: During position fixing, ship's velocity (speed and course) is directly measured by receiving GPS/GLONASS satellite signals. The raw velocity data may change randomly depending on receiving conditions and other factors. You can reduce this random variation by increasing the smoothing. Like with latitude and longitude smoothing, the higher the speed and course smoothing the more smoothed the raw data. If the setting is too high, however, the response to speed and course change slows.

Speed average: This speed is used to calculate the COG and SOG on the data display (see page 7-6).

1. Press the **MENU/ESC** key to open the main menu.
2. Select [8 System Setting] then [5 GNSS].
3. Select [2 GPS Smoothing].

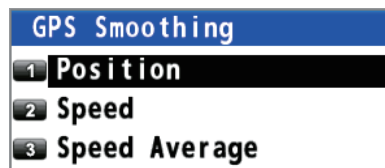

4. Select [1 Position], [2 Speed] or [3 Speed Average].
5. Enter the time for smoothing with the numeric keys.
6. Move the cursor to [Enter] then press the **NU/CU ENT** key.
7. Press the **MENU/ESC** key to close the main menu.

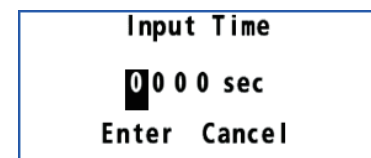

9.3.3 How to set the positioning condition

Satellite elevation

You can set the minimum elevation of satellites to use to fix position.

1. Press the **MENU/ESC** key to open the main menu.
2. Select [8 System Setting] then [5 GNSS].
3. Select [3 Condition].

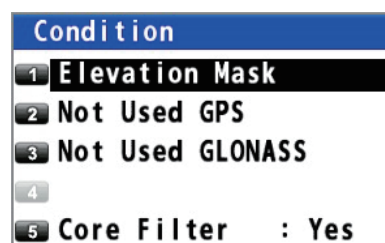

9. OTHER FUNCTIONS

4. Select [1 Elevation Mask].
5. Enter the elevation with the numeric keys.
6. Move the cursor to [Enter] then press the **NU/CU ENT** key.
7. Press the **MENU/ESC** key to close the main menu.

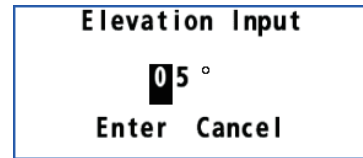

Disable satellite

Every GPS/GLONASS satellite is broadcasting abnormal satellite number(s) in its Almanac, which contains general orbital data about all GPS/GLONASS satellites. Using this information, the GPS/GLONASS receiver automatically eliminates any malfunctioning satellite from the GPS/GLONASS satellite schedule. However, the Almanac sometimes may not contain this information. You can disable an inoperative satellite manually. Enter satellite numbers (up to three satellites) in three digits.

1. Press the **MENU/ESC** key to open the main menu.
2. Select [8 System Setting] then [5 GNSS].
3. Select [3 Condition].
4. Select [2 Not Used GPS] or [3 Not Used GLONASS].
5. Enter the satellite numbers with the numeric keys.
6. Move the cursor to [Enter] then press the **NU/CU ENT** key.
7. Press the **MENU/ESC** key to close the main menu.

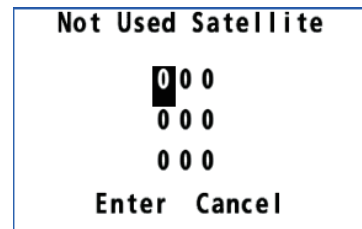

Core filter

1. Press the **MENU/ESC** key to open the main menu.
2. Select [8 System Setting] then [5 GNSS].
3. Select [3 Condition].
4. Select [5 Core Filter].
5. Select [1 No] or [2 Yes].
[1 No]: The tracking sensitivity is better than [Yes], however the ship's track is traced less smoothly than [Yes].
[2 Yes]: The ship's track is traced smoother than [No], however the tracking sensitivity is not as good as [No].
The default setting is [2 Yes]. When selecting [1 No], the confirmation message appears.

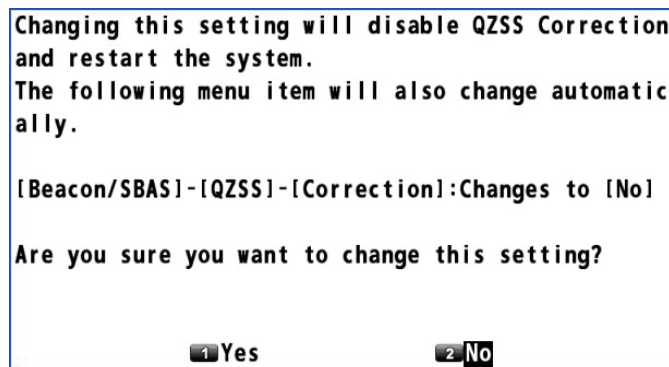

6. Select [1 Yes]. The GP-170 restarts. [Correction] of [QZSS] in the [Beacon/SBAS] menu is automatically set to [No] (see section 9.4.4).

9.3.4 How to select the RAIM function

RAIM (Receiver Autonomous Integrity Monitoring) is a diagnostic function which tests the accuracy of the GPS signal. To use the RAIM function, enter the range (from own ship in meters) for which you want to know position confidence. The receiver estimates position confidence using range value and detected satellite error, and displays (provided the RAIM function is active) the results as one of three levels of position confidence, at the top right-hand corner of the display. The three levels are as follows:

- **Safe:** GPS signal is normal. The positioning accuracy satisfies the setting value.
- **Caution:** RAIM accuracy cannot be calculated. (Signals from more than five GPS satellites are necessary.) The positioning accuracy does not satisfy the setting value.
- **Unsafe:** GPS signal is abnormal, therefore the positioning accuracy is not reliable.

Note: This function is available only for GPS mode.

1. Press the **MENU/ESC** key to open the main menu.
2. Select [8 System Setting] then [5 GNSS].
3. Select [4 RAIM].



4. Select [1 Setting].



5. Select [1 On] or [2 Off].
[On]: Use RAIM function. Go to step 6.
[Off]: Don't use RAIM function. Go to step 9.
6. Select [2 Accuracy Level].
7. Enter the distance with the numeric keys.
8. Move the cursor to [Enter] then press the **NU/CU ENT** key.
9. Press the **MENU/ESC** key to close the main menu.

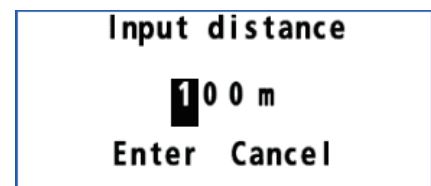

9.3.5 How to select the datum

Your unit is programmed to recognize most of the major chart systems of the world. Although the WGS84 system, the GPS standard, is now widely used other categories of charts still exist. Select the same datum which is used in your nautical charts. Select [WGS84] (default setting), [WGS72] or [Other] (enter the datum number).

1. Press the **MENU/ESC** key to open the main menu.
2. Select [8 System Setting] then [5 GNSS].

9. OTHER FUNCTIONS

3. Select [5 Datum].
4. Select an option. For [6 Other], go to step 5. For others, go to step 7.

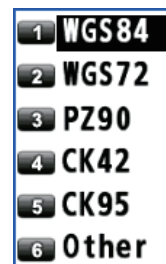

5. Enter the datum number with the numeric keys.
6. Move the cursor to [Enter] then press the **NU/CU ENT** key.
7. Press the **MENU/ESC** key to close the main menu.

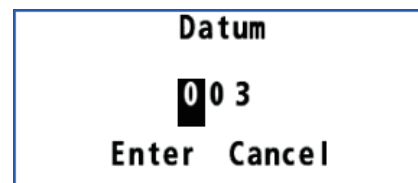

9.3.6 How to set the initial position

You can set the initial position to use when the equipment is restarted. If you restart the equipment in the vicinity of the set position, obtaining a position fix is faster.

1. Press the **MENU/ESC** key to open the main menu.
2. Select [8 System Setting] then [5 GNSS].
3. Select [6 Init Position].
4. Enter the position with the numeric keys. To change the coordinate, select "N" or "E" then press one of keys from 0 to 9.
5. Move the cursor to [Enter] then press the **NU/CU ENT** key.
6. Press the **MENU/ESC** key to close the main menu.

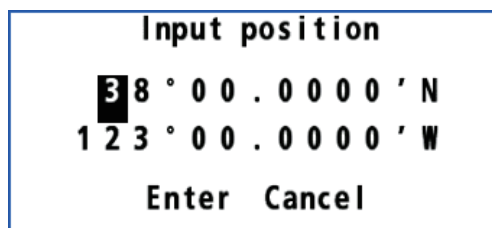

9.3.7 How to set the positioning cycle

You can set the positioning cycle. Position is updated faster with the 5Hz or 10Hz setting, however the accuracy may not be as good as with the 1Hz setting. It is recommended to use the 1Hz setting for vessels other than high speed craft.

1. Press the **MENU/ESC** key to open the main menu.
2. Select [8 System Setting] then [5 GNSS].
3. Select [8 Cycle].



- Select [1 1Hz], [2 5Hz]* or [3 10Hz]*. The confirmation message appears.
*: These options are available for the GPS or Multi mode.

Changing this setting will disable QZSS Correction and restart the system.
The following menu item will also change automatically.

[Beacon/SBAS]-[QZSS]-[Correction]:Changes to [No]

Are you sure you want to change this setting?

1 Yes **2** No

Note: When [Correction] of [QZSS] in the [Beacon/SBAS] menu is set to [Yes], this setting is fixed to [1Hz] (see section 9.4.4).

- Select [1 Yes]. The GP-170 restarts.

9.3.8 How to turn the anti-multipath mode on/off

You can prevent multipath, reflection of the satellite signal by some object, to prevent position “jump”.

- Press the **MENU/ESC** key to open the main menu.
- Select [8 System Setting] then [5 GNSS].
- Select [9 Anti-Multipath Filter].

1 On
2 Off

- Select [1 On] or [2 Off]. The confirmation message appears.

A restart is required after setting.
Do you continue to do so?

1 Yes **2** No

- Select [1 Yes]. The GP-170 restarts.

9.4 Beacon/SBAS Menu

This menu sets the beacon and SBAS.

Note: When the positioning method is GLONASS (see subsection 9.3.1), you cannot set the menus for SBAS.

9.4.1 How to select the differential corrections to use

1. Press the **MENU/ESC** key to open the main menu.
2. Select [8 System Setting] then [6 Beacon/SBAS].

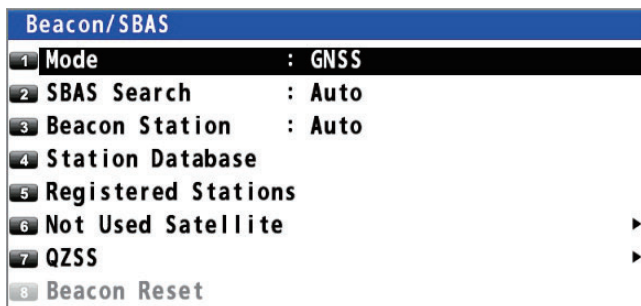

3. Select [1 Mode].

Note: This menu is not available when [3 Type approval Mode] is set to [2 Russia] (see the Installation Manual) and [1 Method] is set to [4 Multi] (see subsection 9.3.1). In this case, [1 Mode] is fixed to [1 GNSS].

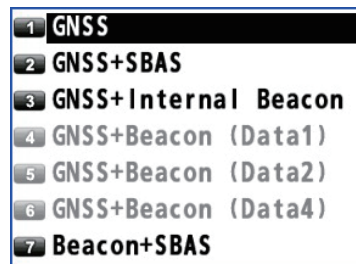

4. Select an option.

[GNSS]: Uses neither beacon nor SBAS for positioning.

[GNSS+SBAS]: Uses SBAS.

[GNSS+Internal Beacon]*: Uses internal beacon.

[GNSS+Beacon (Data1, Data2 or Data4)*]: Uses external beacon.

[Beacon+SBAS]: Switches mode among differential (beacon), SBAS and no use. The priority is Differential (beacon) > SBAS > No use.

*: See the table on the next page.

Menu item	With internal DGPS/DGLONASS beacon receiver	Without internal DGPS/DGLONASS beacon receiver
GNSS+Internal Beacon	Selectable	Not selectable
GNSS+Beacon (Data1, Data2 or Data4)	Not selectable	Selectable

If you select other than [1 GNSS], the confirmation message as shown in the right figure appears. Select [1 Yes] to restart the GP-170. Also, the setting for [Correction] of [QZSS] in the [Beacon/SBAS] menu is automatically set to [No] (see section 9.4.4).

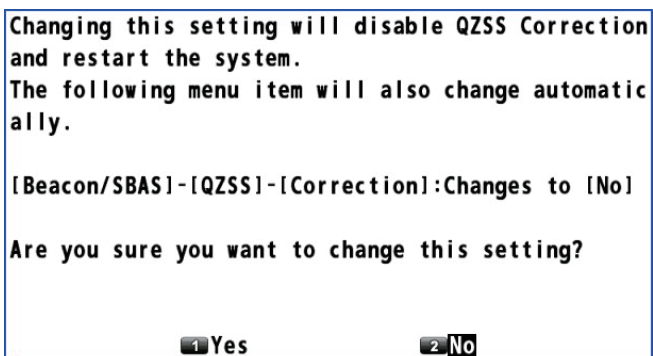

5. Press the **MENU/ESC** key to close the main menu.

9.4.2 How to set SBAS and beacon

SBAS

1. Press the **MENU/ESC** key to open the main menu.
2. Select [8 System Setting] then [6 Beacon/SBAS].
3. Select [2 SBAS Search].



4. Select [1 Auto] or [2 Manual].
 [Auto]: Automatically selects the satellite on the highest elevation among available satellites. Go to step 7.
 [Manual]: Selects the satellite manually. Go to step 5.
5. Enter the satellite number with the numeric keys (setting range: 120 to 138).
6. Move the cursor to [Enter] then press the **NU/CU ENT** key.
7. Press the **MENU/ESC** key to close the main menu.

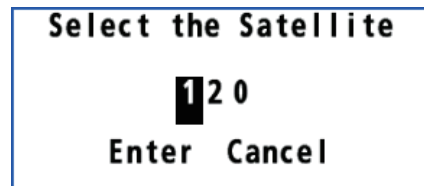

Beacon

1. Press the **MENU/ESC** key to open the main menu.
2. Select [8 System Setting] then [6 Beacon/SBAS].
3. Select [3 Beacon Station].

4. Select [1 Auto], [2 Set Parameter] or [3 Select Station ID].

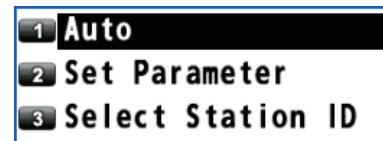

[Auto]: Automatically selects the nearest station among available stations. Go to step 8.

[Set Parameter]: Selects the station with entering the frequency or selecting the bit rate. Go to step 5.

[Select Station ID]: Selects the station from the station list (requires DGPS/DG-LONASS internal beacon receiver). Go to step 7.

5. Select [1 Frequency] or [2 Bit Rate].

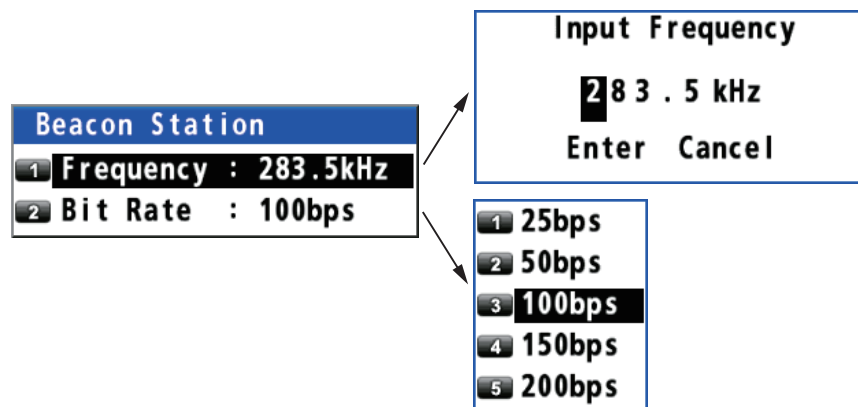

6. For [Frequency], enter the frequency with the numeric keys and move the cursor to [Enter] then press the **NU/CU ENT** key.
 For [Bit Rate], select the bit rate from five options.
 Go to step 8.

9. OTHER FUNCTIONS

- Use the cursorpad (▲ or ▼) to select the station ID then press the **NU/CU ENT** key.
- Press the **MENU/ESC** key to close the main menu.

9.4.3 How to open the station data

Station database

Note: This menu requires internal DGPS/DGLONASS beacon receiver.

- Press the **MENU/ESC** key to open the main menu.
- Select [8 System Setting] then [6 Beacon/SBAS].
- Select [4 Station Database] to show the [Station List] for 1020 station data.

BEACON		WGS84 34°23.4567'N 134°23.4567'E GP-S3D Safe		
Station List				
No.	Station	Information		
0001	EAZAKI	Station Name	: EAZAKI	
0002	ABASHIRI	Station ID	: 0500	
0003	MATSUMAE	ID REF1/REF2	: 0434/0434	
0004	HAMADA	Latitude	: 35° 49.6508'N	
0005	TANGO	Longitude	: 136° 31.8592'E	
0006	SAKATA	Datum	: WGS84	
0007	-----	Operation Status	: 00	
0008	INUBOSAKI	Frequency	: 320.5kHz	
0009	HACHIJOJJ	Bit Rate	: 200bps	
0010	NAGOYA	Distance	: 20NM	

0-9	Jump to the ID(All digit input)
▲▼	Select an active Item
NU/CU ENT	Go to the popup menu
MENU ESC	Close

Jump: 0001

Enter the station no. (e.g. "0001") with the numeric key then press the **NU/CU ENT** key to display the information of the selected station at the right side of the screen.

- Press the **MENU/ESC** key to close the main menu.

Registered stations

You can register up to 20 beacon stations.

Note: This menu requires internal DGPS/DGLONASS beacon receiver.

- Press the **MENU/ESC** key to open the main menu.
- Select [8 System Setting] then [6 Beacon/SBAS].
- Select [5 Registered Stations] to show the [Edit Station Information] list.

BEACON					
WGS84 34°23.4567'N 134°23.4567'E GP-S3D Safe					
Edit Station Information					
	Station	LAT	LON	FREQ	Bit Rate
01	EAZAKI	35° 49'N	136° 31'E	320.5 kHz	200 bps
02	ABASHIRI	36° 01'N	135° 35'E	315.0 kHz	150 bps
03	MATSUMAE	36° 06'N	134° 55'E	302.5 kHz	50 bps
04	HAMADA	36° 08'N	134° 09'E	297.5 kHz	25 bps
05	TANGO	36° 15'N	133° 26'E	290.0 kHz	100 bps
06	SAKATA	36° 22'N	132° 18'E	388.0 kHz	150 bps
07	-----	--° --'N	--° --'E	---.--- kHz	--- bps
08	INUBOSAKI	36° 30'N	131° 08'E	321.0 kHz	200 bps
09	HACHIJOJJ	36° 38'N	129° 55'E	305.5 kHz	200 bps
10	NAGOYA	36° 46'N	128° 38'E	280.5 kHz	200 bps

▲▼	Select an active Item
MENU ESC	Close

- Use the cursorpad (**▲** or **▼**) to select ID no. then press the **NU/CU ENT** key.

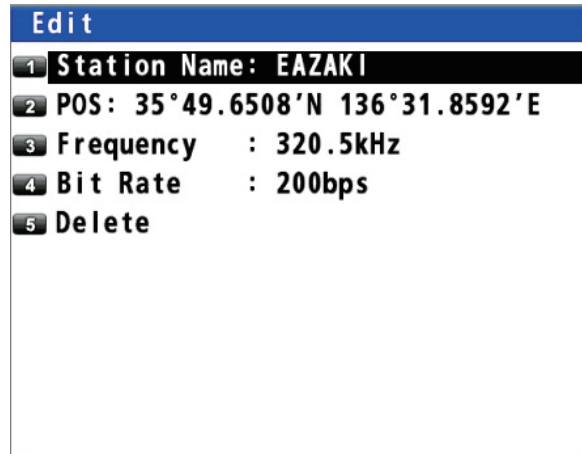

- Edit the name, position, frequency or bit rate. Select [5 Delete] to delete the selected station.
- Press the **MENU/ESC** key to close the main menu.

Disable satellite

You can disable a maximum of three satellites.

- Press the **MENU/ESC** key to open the main menu.
- Select [8 System Setting] then [6 Beacon/SBAS].
- Select [6 Not Used Satellite].



- Select [1 SBAS] or [2 QZSS_L1C/A].
- Enter the disable satellite numbers with the numeric keys (setting range: 120 to 138 for SBAS, 193 to 196 and 199 for QZSS_L1C/A).
- Move the cursor to [Enter] then press the **NU/CU ENT** key.
- Press the **MENU/ESC** key to close the main menu.



9.4.4 How to set QZSS

Note: When the positioning method is GLONASS (see subsection 9.3.1), you cannot set the menus for QZSS.

- Press the **MENU/ESC** key to open the main menu.
- Select [8 System Setting] then [6 Beacon/SBAS].
- Select [7 QZSS]. For [Positioning], go to step 4. For [Correction], go to step 6.



- Select [1 Positioning].
- Select [1 Yes] to use QZSS for positioning, [2 No] if you do not use QZSS. The menu closes and the setting is reflected.

9. OTHER FUNCTIONS

6. Select [2 Correction].
7. Select [1 Yes] to use QZSS correction for positioning, [2 No] if you do not use QZSS correction. If you select [1 Yes], the following confirmation message appears.

Changing this setting will restart the system in order to start using QZSS Correction. The following menu items will also change automatically.

**[Beacon/SBAS]-[Mode]:Changes to [GNSS]
[GNSS]-[Cycle]:Changes to [1Hz]
[GNSS]-[Condition]-[Core Filter]:Changes to [Yes]**

Are you sure you want to change this setting?

1 Yes 2 No

Select [1 Yes] to restart the GP-170. Also, the following menu settings automatically change.

- [Beacon/SBAS] – [Mode]: [GNSS] (See section 9.4.1.)
 - [GNSS] – [Cycle]: [1Hz] (See section 9.3.7.)
 - [GNSS] – [Condition] – [Core Filter]: [Yes] (See "Core filter" on page 9-6.)
8. Press the **MENU/ESC** key to close the main menu.

9.5 Language

The available languages are English and Japanese.

1. Press the **MENU/ESC** key to open the main menu.
2. Select [8 System Setting] then [1 Language].
3. Select a language.
4. Press the **MENU/ESC** key to close the main menu.



9.6 I/O Menu

Besides its fundamental function of displaying position, the GP-170 can also output various data to external equipment. Before outputting data to external equipment, first determine what data the external equipment requires. Output only necessary data to ensure data will be output correctly.

All data transmitted by marine electronics equipment are prefixed with a two character code called a talker. The same talker must be shared by the transmitting and receiving equipment to transmit and receive data successfully.

9.6.1 How to set the output 1, 2, 3 or 4

Note: The [Format], [Talker], and [BPS] menus (steps 6 to 11) are for serviceman.

1. Press the **MENU/ESC** key to open the main menu.
2. Select [7 I/O].

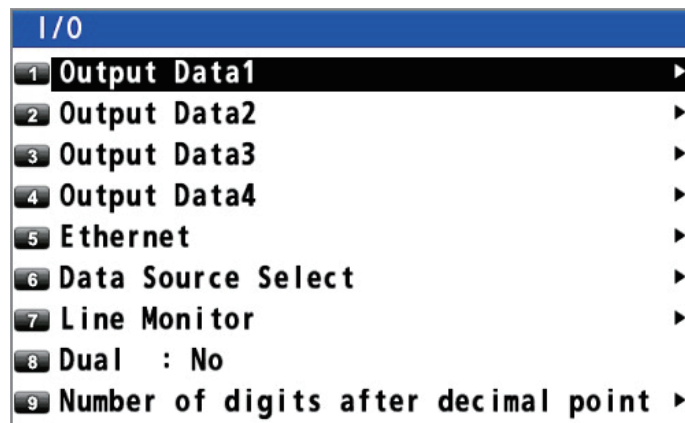

3. Select [1 Output Data1].

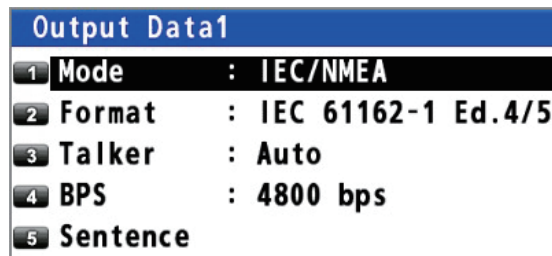

4. Select [1 Mode].
5. Select [1 IEC/NMEA] or [2 RTCM].
[IEC/NMEA]: NMEA sentence output
[RTCM]: Binary output
6. Select [2 Format].
7. Select [1 IEC 61162-1 Ed.4/5], [2 IEC 61162-1 Ed.3], [NMEA V2.0] or [NMEA V1.5].
8. Select [3 Talker].
9. Select [1 Auto]*, [2 GP] or [4 GN].
*: Select [1 Auto] for SOLAS ships.

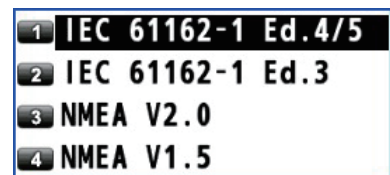

9. OTHER FUNCTIONS

10. Select [4 BPS].
11. Select [1 4800 bps], [2 9600 bps] or [3 38400 bps].
12. Select [5 Sentence].

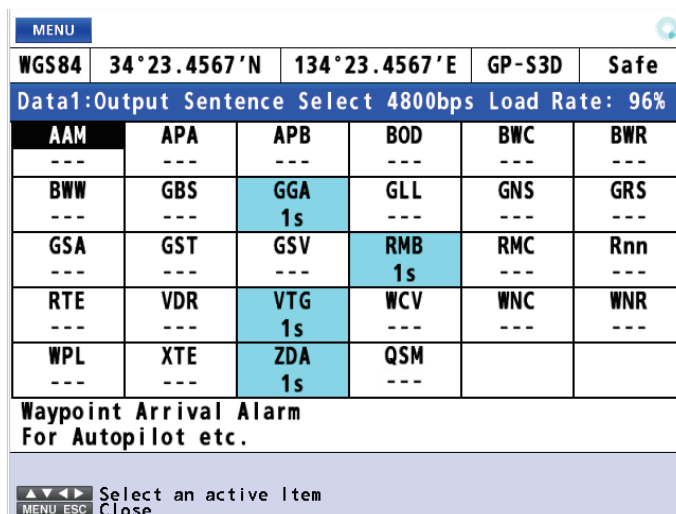
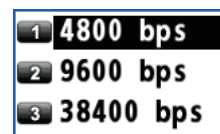

Note: The following sentences are not output until initial positioning is achieved. DTM, GBS, GGA, GLL, GNS, GRS, GST, RMC, ZDA

13. Use the cursorpad to select the sentence then press the **NU/CU ENT** key.
14. Use the cursorpad (◀ or ▶) to select the TX interval. TX interval is available in [- - -] (off), [0.1s]*, [0.2s]*, [1s], [2s], [3s], [4s], [5s], [6s], [10s], [15s], [20s], [30s], [60s] and [90s].
 - *: Only for GGA**, GLL, GNS, RMC and VTG when selecting [38400 bps] at step 11.
 - **: Only for GPS mode.
15. Press the **NU/CU ENT** key.

Note 1: Keep the Load Rate below 100% when setting the TX intervals. The TX interval for other than the ZDA sentence cannot be guaranteed if the rate exceeds 100%.

Note 2: For the TX interval of [0.1s] or [0.2s], set the positioning cycle (refer to subsection 9.3.7) as follows:

 - For [0.1s], set the positioning cycle at 10Hz.
 - For [0.2s], set the positioning cycle at 5Hz or 10Hz.
16. Set [2 Output Data2], [3 Output Data3] and [4 Output Data4] as well.
17. Press the **MENU/ESC** key to close the main menu.

9.6.2 How to set the Ethernet

1. Press the **MENU/ESC** key to open the main menu.
2. Select [7 I/O] then [5 Ethernet].
3. Select [1 Sentence].
4. Use the cursorpad to select the sentence then press the **NU/CU ENT** key.
5. Use the cursorpad (◀ or ▶) to select the TX interval. TX interval is available in [- - -] (off),

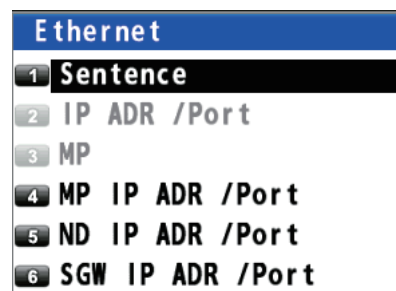

[0.1s]*, [0.2s]*, [1s], [2s], [3s], [4s], [5s], [6s], [10s], [15s], [20s], [30s], [60s] and [90s].

*: Only for GGA, GLL, GNS, RMC and VTG.

6. Press the **NU/CU ENT** key.

Note: For the TX interval of [0.1s] or [0.2s], set the positioning cycle (refer to subsection 9.3.7) as follows:

- For [0.1s], set the positioning cycle at 10Hz.
- For [0.2s], set the positioning cycle at 5Hz or 10Hz.

7. Press the **MENU/ESC** key to close the sentence window.

8. Press the **MENU/ESC** key to open the main menu.

9. Select [7 I/O] then [5 Ethernet].

10. Select [2 IP ADR /Port].

Note: This menu is for serviceman.

IP Address	239 . 192 . 000 . 004
Port	60004
Enter Cancel	

11. Enter the IP address and port (setting range: 49152 to 65535) with the numeric keys. When setting dual configuration (see section 9.7), set “239.192.000.004” for IP address and “60004” for port.

12. Move the cursor to [Enter] then press the **NU/CU ENT** key.

13. Select [3 MP].

14. Select [1 Enable] or [2 Disable]. For [1 Enable], go to step 15. For [2 Disable], go to step 24.

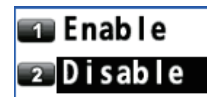

15. Select [4 MP IP ADR /Port].

16. Enter the MP IP address and port with the numeric keys.

17. Move the cursor to [Enter] then press the **NU/CU ENT** key.

18. Select [5 ND IP ADR /Port].

19. Enter the ND IP address and port with the numeric keys.

20. Move the cursor to [Enter] then press the **NU/CU ENT** key.

21. Select [6 SGW IP ADR/Port]

22. Enter the SGW IP address and port with the numeric keys.

23. Move the cursor to [Enter] then press the **NU/CU ENT** key.

24. Press the **MENU/ESC** key to close the main menu.

9.6.3 How to select the input data

1. Press the **MENU/ESC** key to open the main menu.
2. Select [7 I/O] then [6 Data Source Select].

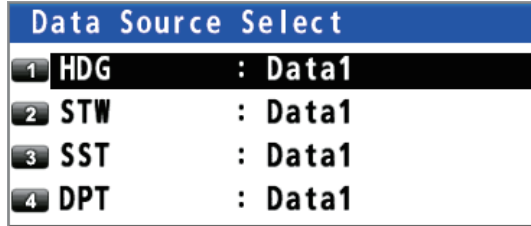

3. Select [1 HDG].
4. Select the port for heading data. For [5 Ethernet], go to step 5. For [1 Data1], [2 Data2] or [4 Data4], go to step 6.

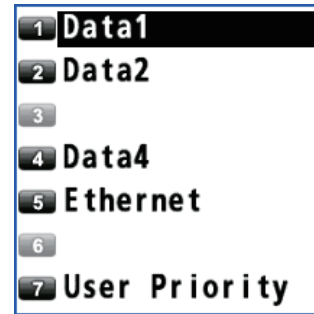

5. When selecting [5 Ethernet], do the following:
 - 1) Press the **ACK/DELETE** key to move the cursor to the leftmost of the input position.

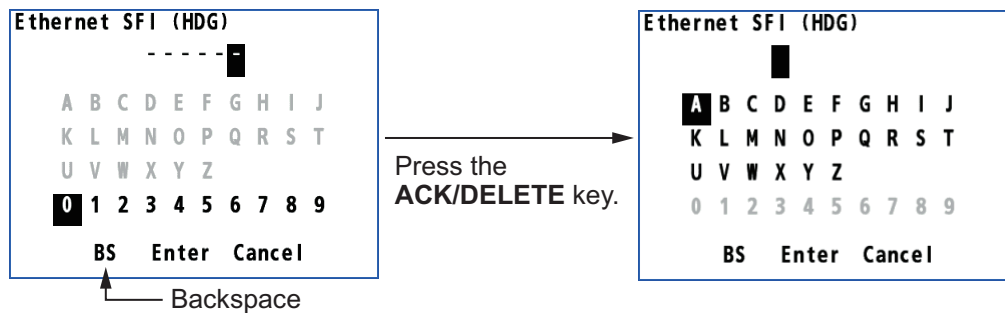

- 2) Enter the Ethernet SFI with the cursorpad and the numeric keys (combination of two alphabets and four numerals). SFI (System Function ID) is an identification code used by the system.
- 3) Move the cursor to [Enter] then press the **NU/CU ENT** key. Go to step 9.

Note: Set the SFI to eliminate overlap with other ones.

6. Select [1 HDG].
7. Select [7 User Priority].
8. Enter the priority for heading data by data number. For example, to set the priority order as Data1, Data2, Data4, enter 1, 2, 4.
9. Set the input data for [2 STW] (speed through water), [3 SST] (sea surface temperature) and [4 DPT] (water depth) as well.

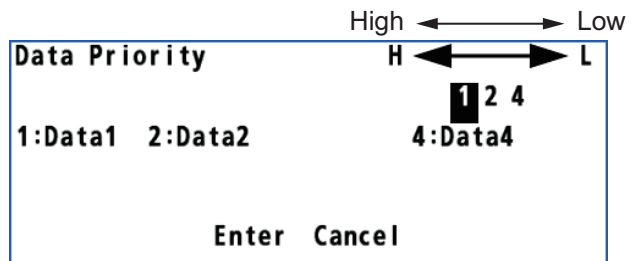

10. Press the **MENU/ESC** key to close the main menu.

9.6.4 Line monitor log

Line monitor

The data output from the data ports (Data1 - Data4) can be monitored, and the data can be saved to a USB flash memory.

1. Press the **MENU/ESC** key to open the main menu.
2. Select [7 I/O] then [7 Line Monitor].

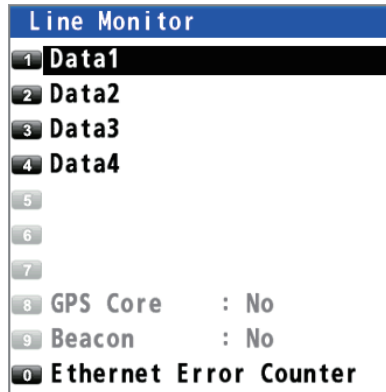

3. Select [Data1] (or 2, 3, 4).

PLOTTER				
WGS84	34°12.3456'N	134°12.3456'E	GP-S3D	Safe
Data1: 4800 bps				No USB
Rx		Tx		
\$YCMTW,027.32,C\$GPZDA,012614.00,01,11,2012,-09,00 42	\$GPZDA,012613.00,01,11,2012,-09,00 45	\$GPDPTM,W84,,00.0000,N,00.0000,E,W84 41		
\$YCMTW,027.32,C\$GPZDA,012614.00,01,11,2012,-09,00 42	\$GPZDA,012613.00,01,11,2012,-09,00 45	\$GPGGA,012614.00,0844.7963,S,11512.6084,E,2,6,0.7,15,M,,M, , 78		
\$YCMTW,027.32,C\$GPZDA,012614.00,01,11,2012,-09,00 42	\$GPZDA,012613.00,01,11,2012,-09,00 45	\$GPRVTG,258.0,T,256.5,M,0.1,N,0.2,K,D 2E		
\$YCMTW,027.32,C\$GPZDA,012614.00,01,11,2012,-09,00 42	\$GPZDA,012613.00,01,11,2012,-09,00 45	\$GPDPTM,W84,,00.0000,N,00.0000,E,W84 41		
\$YCMTW,027.32,C\$GPZDA,012614.00,01,11,2012,-09,00 42	\$GPZDA,012613.00,01,11,2012,-09,00 45	\$GPGGA,012614.00,0844.7963,S,11512.6084,E,2,6,0.7,15,M,,M, , 78		
\$YCMTW,027.32,C\$GPZDA,012614.00,01,11,2012,-09,00 42	\$GPZDA,012613.00,01,11,2012,-09,00 45	\$GPRVTG,258.0,T,256.5,M,0.1,N,0.2,K,D 2E		
\$YCMTW,027.32,C\$GPZDA,012614.00,01,11,2012,-09,00 42	\$GPZDA,012613.00,01,11,2012,-09,00 45	\$GPDPTM,W84,,00.0000,N,00.0000,E,W84 41		
\$YCMTW,027.32,C\$GPZDA,012614.00,01,11,2012,-09,00 42	\$GPZDA,012613.00,01,11,2012,-09,00 45	\$GPGGA,012614.00,0844.7963,S,11512.6084,E,2,6,0.7,15,M,,M, , 78		
\$YCMTW,027.32,C\$GPZDA,012614.00,01,11,2012,-09,00 42	\$GPZDA,012613.00,01,11,2012,-09,00 45	\$GPRVTG,258.0,T,256.5,M,0.1,N,0.2,K,D 2E		

To save the log data to a USB flash memory, go to step 4. Otherwise, go to step 7.

4. Connect a USB flash memory in the USB port.
 - Note 1:** Do not use an encrypted USB flash memory.
 - Note 2:** Keep water away from the unit when the USB flash memory is inserted. The USB port is not waterproof while its cover is removed.
5. Press the **NU/CU ENT** key.
 - Note:** Do not save the log from multiple ports simultaneously. The log data may not be saved correctly depending on the specification or capacity of the USB flash memory.
6. Press the **NU/CU ENT** key to complete the saving.
 - Note:** Remove the USB flash memory after the saving is completed.
7. Press the **MENU/ESC** key to close the main menu.

Ethernet error counter

1. Press the **MENU/ESC** key to open the main menu.
2. Select [7 I/O] then [7 Line Monitor].
3. Select [0 Ethernet Error Counter]. The data traffic value (Mbps) is displayed at the top right-hand corner as shown in the right figure. Press the **ACK/DELETE** key to reset all counts to 0.
4. Press the **MENU/ESC** key to close the main menu.

PLOTTER					
WGS84	34°12.3456'N	134°12.3456'E	GP-S3D	Safe	
Ethernet Error Counter				2.45 Mbps	
Ethernet Error				Count	
1	UDP Checksum Error			000	
2	Invalid Header			000	
3	Incorrect TAG Block			000	
4	TAG Block Checksum Error			000	
5	TAG Block Syntax Error			000	
6	TAG Block Framing Error			000	
7	Incorrect Sentence			000	
MENU/ESC Close					

9.6.5 How to set the number of digits displayed for distance and speed

To set the number of digits displayed after the decimal point for distance and speed output sentences, do the following:

1. Press the **MENU/ESC** key to open the main menu.
2. Select [7 I/O] then [9 Number of digits after decimal point].
3. Select [1 Distance] or [2 Speed].
4. Select the number of digits to display.
5. Press the **MENU/ESC** key to close the main menu.

Number of digits after decimal point		
1	Distance	: 3
2	Speed	: 3

1	1
2	2
3	3

9.7 How to Set Dual Configuration

You can configure two dual differential GNSS navigator systems and an interface unit (IF-2550).

The information shared between two display units is as follows:

- Destination
- Mark
- Waypoint
- Route
- [Not Used Satellite] (Only for GPS satellites)
- [Arrival/Anchor] setting
- Specified distance for the arrival notice
- Specified distance for the anchor notice
- [XTE] setting ([Off], [On])
- Specified distance for the XTE notice
- [Trip] setting ([Stop], [Start/Reset], [Clear])
- [Range] setting for [Trip]
- Alert [Mode] ([Alert I/F 1], [Alert I/F 2], [Legacy])
- [Remote Ack I/F] ([Ack], [BuzzerStop])
- [Ship Speed] setting ([Off], [In], [Out])
- [Ship Speed] range setting
- [RAIM] setting ([On], [Off])
- RAIM [Accuracy Level]
- ECDIS sync [Mode] ([On], [Off])
- [ECDIS IP ADR]
- [ECDIS SFI]

1. Press the **MENU/ESC** key to open the main menu.
2. Select [7 I/O] then [8 Dual].
3. Select [1 No], [2 Serial (Data2)] or [3 Ethernet].
 [No]: Don't set dual configuration.
 [Serial (Data2)]: Sets dual configuration using data2.
 [Ethernet]: Sets dual configuration using Ethernet.
4. Press the **MENU/ESC** key to close the main menu.



9.8 How to Set ECDIS Sync Configuration

When connecting the ECDIS (FMD-3x00 series) via LAN, you can display the ECDIS-set monitored route on the display of the GP-170.

1. Press the **MENU/ESC** key to open the main menu.
2. Select [3 Navigation] then [4 ECDIS Sync].

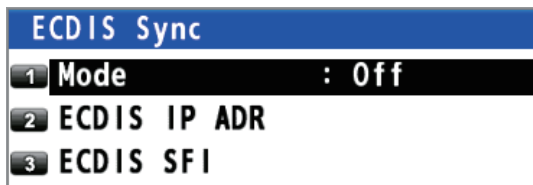

3. Select [2 ECDIS IP ADR].

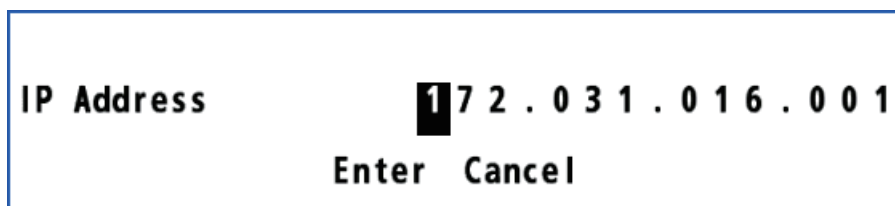

4. Enter the IP address for the connected ECDIS with the numeric keys.
5. Move the cursor to [Enter] then press the **NU/CU ENT** key.
6. Select [3 ECDIS SFI].
7. Press the **ACK/DELETE** key to move the cursor to the leftmost of the input position.

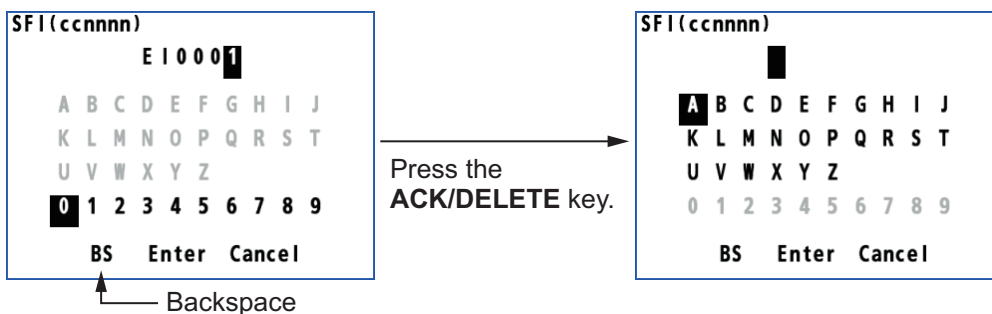

8. Enter the SFI for the connected ECDIS with the cursorpad and the numeric keys (combination of two alphabets and four numerals).
9. Move the cursor to [Enter] then press the **NU/CU ENT** key.
10. Select [1 Mode].



11. Select [2 On].

Note: When selecting [2 On], you can not set a destination on the GP-170.

12. Press the **MENU/ESC** key to close the main menu.

To turn the synchronization off, select [1 Off] at step 11.

Note 1: When selecting [1 Off] during the synchronization with the ECDIS, the destination is canceled on the GP-170.

Note 2: The GP-170 uses waypoint information from the ECDIS when they are synced to one another. Therefore, some delay occurs between the arrival notice and

next waypoint. This is not an indication of malfunction but the difference of criterion for waypoint updating between the ECDIS and the GNSS receiver. If you do not need the arrival notice on the GP-170, turn it off (see subsection 6.2.1).

Note 3: The no. 100 route on the route list is reserved for the monitored route output from the ECDIS. This route is automatically written over when the GP-170 receives a new monitored route.

9.9 User Password Settings

You can set a password to prevent unauthorized entry into certain menus. The default setting is no password. When setting the password for the first time, the [Please enter your password] window does not appear. Make sure to register a password by the administrator (for example, by the captain).

1. Press the **MENU/ESC** key to open the main menu.
2. Select [8 System Setting] then [2 Plotter].
3. Select [9 Password]. Below window is shown.



How to set and change the password

1. Select one of the menus that require password authentication.
2. Enter the password and then select [Enter]. If the password is correct, below window appears.

Note: When setting the password for the first time, the [Please enter your password] in step 1 is not shown and the below window directly appears to set the password.

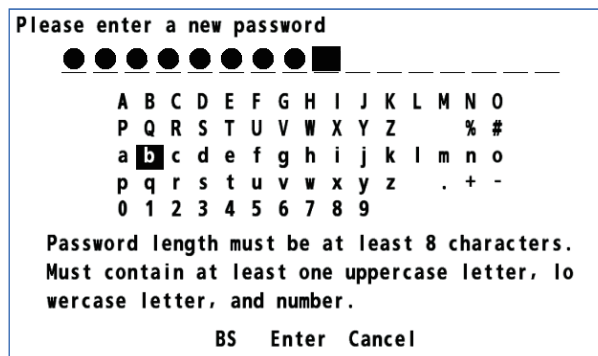

3. Use the software keyboard and enter the password according to the rules shown on the screen, then select [Enter].
4. Enter the new password again to confirm and select [Enter]. If the password matches, the message "new password is set" appears. If the password does not match, enter the password again.

How to reset the password

1. Select [2 Reset password]. Below window appears.

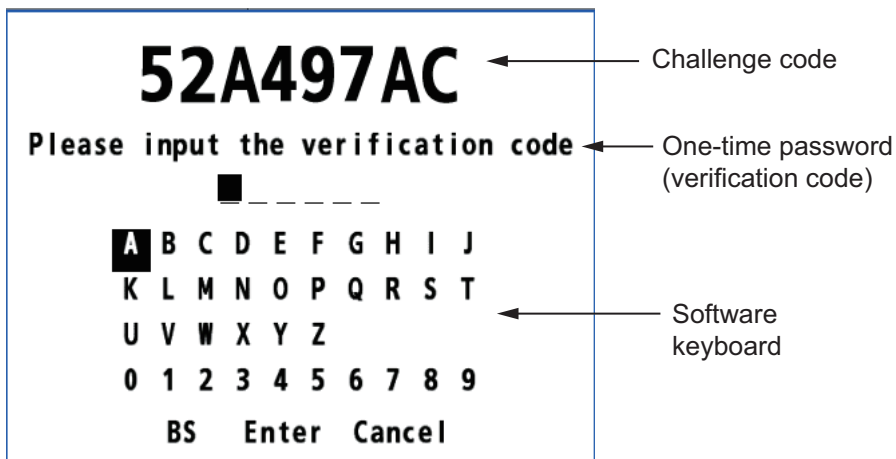

2. Contact your dealer and generate a one-time password (verification code) from the challenge code on the screen and enter the password using the software keyboard.
3. To go one letter back, select [BS].
4. To finish, select [Enter] then press the **NU/CU ENT** key.
5. Press the **MENU/ESC** key to close the main menu.

Note 1: If more than 12 hours is passed, or if the entered one-time password (generated verification code) is incorrect 10 times in a row, the password becomes invalid.

Note 2: To generate a new one-time password, restart the system or wait for more than 10 minutes.

Password authentication

Note 1: To display the password authentication menu, the [Type Approval Mode] in the [Service] menu needs to be set to [None].

Note 2: The [Service] menu is for service technician only.

1. Select [3 Password authentication].
2. Enter the set password, then select [Enter].
3. Select to enable or disable the password authentication as appropriate.
 [Enable]: The password authentication is required for certain menus.
 [Disable]: The password authentication is disabled for certain menus. Also, The [Change Password] and [Password Reset] menus are disabled (grayed-out).
4. Press the **MENU/ESC** key to close the main menu.

9.10 How to Set the Demo Mode

A demo mode, which shows internally generated navigation data, is provided to acquaint you with the features of the GP-170. You can set the demo mode as follows:

1. Press the **MENU/ESC** key to open the main menu.
2. Select [8 System Setting] then [8 Demo].



3. Select [1 Parameter].

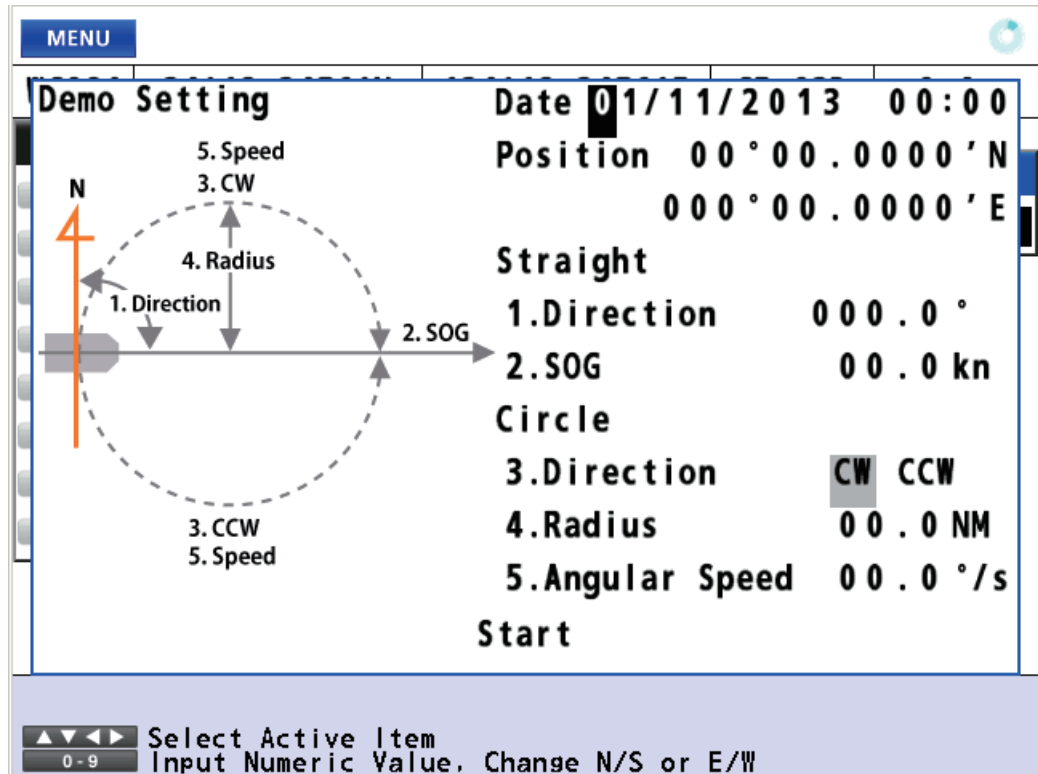

4. Enter each setting with the numeric keys referring to the above figure.
 - [Date]: Set the starting date and time in UTC.
 - [Position]: Set the starting position. To change the coordinate, select "N" or "E" then press one of keys from **0** to **9**.
 - [1. Direction]: Set the direction for translatory movement.
 - [2. SOG]: Set the speed for translatory movement in kn.
 - [3. Direction]: Select the direction for rotary motion from [CW] (clockwise) and [CCW] (counterclockwise).
 - [4. Radius]: Set the radius for rotary motion in NM.
 - [5. Angular Speed]: Set the angular speed for rotary motion.
5. Move the cursor to [Start] then press the **NU/CU ENT** key. The equipment re-starts. The **SIM** icon (simulation) appears at the top left corner of the screen.

Note: To cancel the demo mode, turn the power off and on.

9. OTHER FUNCTIONS

This page is intentionally left blank.

10. MAINTENANCE

NOTICE

Do not apply paint, anti-corrosive sealant or contact spray to plastic parts or equipment coating.

Those items contain products that can damage plastic parts and equipment coating.

10.1 Maintenance

Regular maintenance is important to maintain performance. Check the following points to help maintain performance.

- Check that connectors on the rear panel are firmly tightened and free of rust.
- Check that the ground system is free of rust and the ground wire is tightly fastened.
- Check that battery terminals are clean and free of rust.
- Check if the antenna unit is damaged. If damaged, replace.
- Dust or dirt may be removed from the cabinet with a soft cloth. Water-diluted mild detergent may be used if desired. DO NOT use chemical cleaners to clean the display unit; they may remove paint and markings.
- Wipe the LCD carefully to prevent scratching, using tissue paper and an LCD cleaner. To remove dirt or salt deposits, use an LCD cleaner, wiping slowly with tissue paper so as to dissolve the dirt or salt. Change paper frequently so the salt or dirt will not scratch the LCD. Do not use solvents such as thinner, acetone or benzene for cleaning. Also, do not use degreaser or antifog solution, as they can strip the coating from the LCD.
- Check the audit log (password is required).

Life of LCD

GP-170 is equipped with either LCD NL6448BC-01F or COM57H5N32XSC.

- For NL6448BC18-01F: The lifetime of LCD is approximately 60,000 hours.
- For COM57H5N32XSC: The lifetime of LCD is approximately 70,000 hours.

The actual number of hours depends on ambient temperature and humidity. When the brilliance cannot be raised sufficiently, ask your dealer about replacement.

10.2 Fuse Replacement

 WARNING
<p>Use the proper fuse.</p> <p>A wrong fuse can damage the equipment and cause fire.</p>

The fuse (type: FGBO-A 250V 2A PBF) in the power cable protects against overvoltage and equipment trouble. If you cannot turn on the power, first check the fuse. If the fuse has blown, replace the fuse with the specified fuse. If the fuse blows again after replacement, contact your dealer.

10.3 Troubleshooting

This section provides simple troubleshooting procedures which the user can follow to restore normal operation. If you cannot restore normal operation, do not attempt to check inside the unit. Any trouble should be referred to a qualified technician.

Symptom	Remedy
You cannot turn on the power.	<ul style="list-style-type: none"> • Check for damaged power cable and connector. • Check if the power cable is firmly fastened. • Check the battery for proper voltage output. • Check if the fuse in the power cable has blown.
No picture appears.	Adjust the brilliance using the BRILL key.
There is no response when a key is pressed.	Turn off and on the power. If no change, ask your dealer.
Position is not fixed.	<ul style="list-style-type: none"> • Check if the antenna connector is firmly fastened. • Check the number of satellites on the integrity display. If there are two or less, check for obstructions between antenna unit and satellites. • Clear the GPS memory on the [8 System Setting] - [9 Clear Memory] - [2 Clear GPS] menu.
Position is wrong.	<ul style="list-style-type: none"> • Check if the correct geodetic chart system is selected on the [8 System Setting] - [5 GNSS] - [5 Datum] menu. • Enter the position offset on the [8 System Setting] - [4 Correction, Offset] - [1 Position Offset] menu.
Bearing is wrong.	Check the magnetic variation on the [8 System Setting] - [2 Plotter] - [2 Magnetic Variation] menu.
DC reports cannot be received.	<ul style="list-style-type: none"> • Select [1 Yes] on the [8 System Setting] - [6 Beacon/SBAS] - [7 QZSS] - [2 Correction] menu. • Check if own ship is within the coverage area of QZSS (see page AP-12).
Data are not transmitted to external equipment.	<ul style="list-style-type: none"> • Check if the data format is correct on the [7 I/O] menu. • The TX interval may be set to off. Select the proper interval. • Check the appropriate settings on the external equipment. • Check the connections: <u>GP-170 External equipment</u> TD4-A RD4-A TD4-B RD4-B

10.4 Equipment Information

You can display information about this equipment from the menu.

1. Press the **MENU/ESC** key to open the main menu.
2. Select [6 Maintenance] then [1 Information].

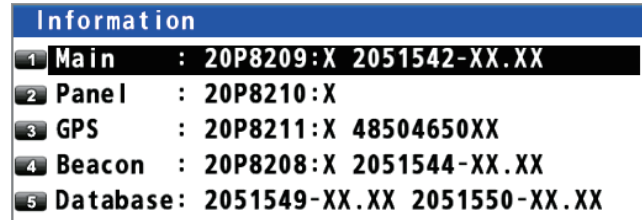
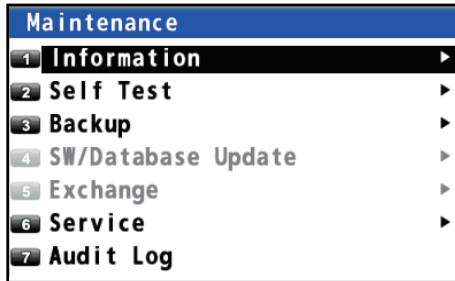

X: Board version no.
XX: Program version no.

3. Select [1 Main], [2 Panel], [3 GPS], [4 Beacon] (requires internal DGPS/DGLON-ASS beacon receiver) or [5 Database].

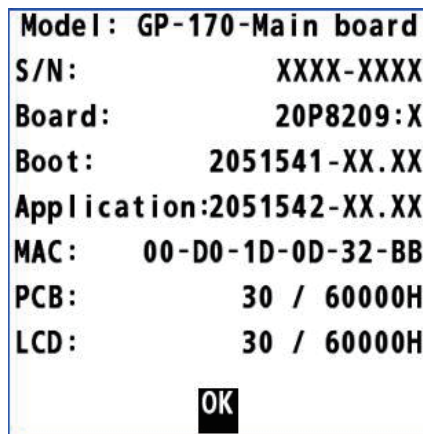

Main

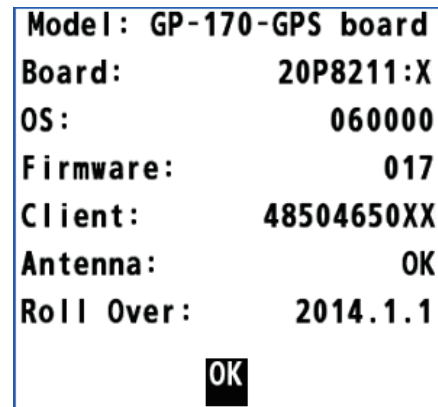

GPS

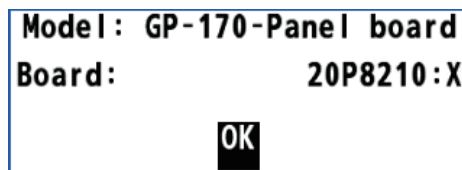

Panel

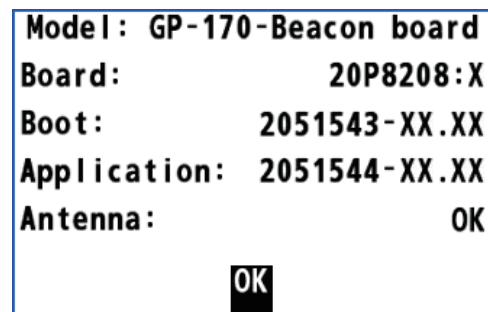

Beacon

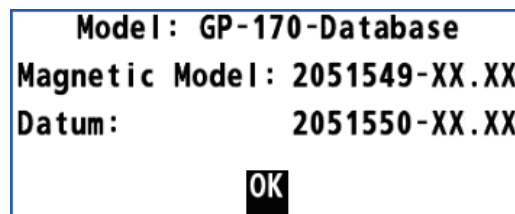

Database

4. Press the **NU/CU ENT** key to close each information window.
5. Press the **MENU/ESC** key to close the main menu.

10.5 Self Test

The self test checks the ROM, RAM, input/output data, GNSS core, Beacon core, keyboard and LCD performance. The user can do the tests to help the service technician in troubleshooting.

Memory test

1. Press the **MENU/ESC** key to open the main menu.
2. Select [6 Maintenance] then [2 Self Test].

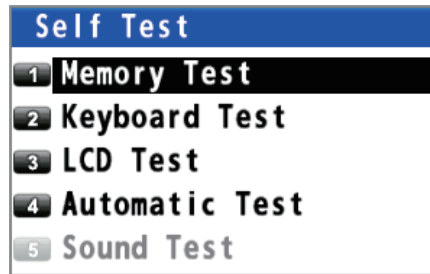

3. Select [1 Memory Test]. The test results are displayed as "OK", "NG" (No Good) or "--". If any NG is displayed, contact your dealer. The test result of Data1 - 4, checked using a dedicated connector at the factory, is normally displayed as "--".

Self Test: memory, I/O, Data test	
Restart: Push "NU/CU ENT" or "方位モード 入力" Key	
Exit: Push "MENU ESC" or "メニュー 戻る" Key	
Start Time: 2014.04.15 12:18	
Main	GPS
ROM: OK 2014.04.15 12:18	ROM: OK 2014.04.15 12:18
RAM: OK 2014.04.15 12:18	RAM: OK 2014.04.15 12:18
USB: OK 2014.04.15 12:18	Flash: OK 2014.04.15 12:18
Data1: --	Beacon
Data2: --	ROM: OK 2014.04.15 12:18
Data3: --	RAM: OK 2014.04.15 12:18
Data4: --	Memory: OK 2014.04.15 12:18
LAN: OK PHY is OK.	ANT: OK 2014.04.15 12:18

4. Press the **MENU/ESC** key to close the memory test window.

Keyboard test

1. Press the **MENU/ESC** key to open the main menu.
2. Select [6 Maintenance] then [2 Self Test].
3. Select [2 Keyboard Test].

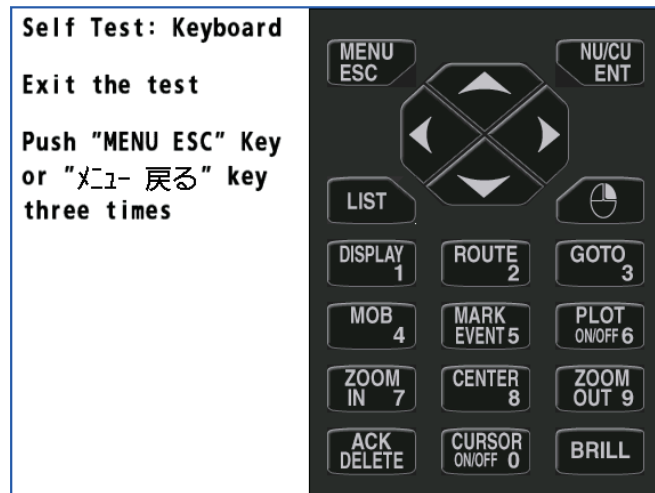

4. Press each key one by one. A key's corresponding location on the display turns blue if the key is normal.
5. Press the **MENU/ESC** key three times to close the keyboard test window.

LCD test

1. Press the **MENU/ESC** key to open the main menu.
2. Select [6 Maintenance] then [2 Self Test].
3. Select [3 LCD Test]. The operation instructions display opens.

Change color pattern
 Push "NU/CU ENT" or "方位モト" 入力" Key

Exit the test
 Push "MENU ESC" or "メニュー戻る" Key

If O.K., start the LCD test
 to push "NU/CU ENT" or "方位モト" 入力" Key

- Press the **NU/CU ENT** key. Each press of this key changes the LCD pattern in the sequence shown below.

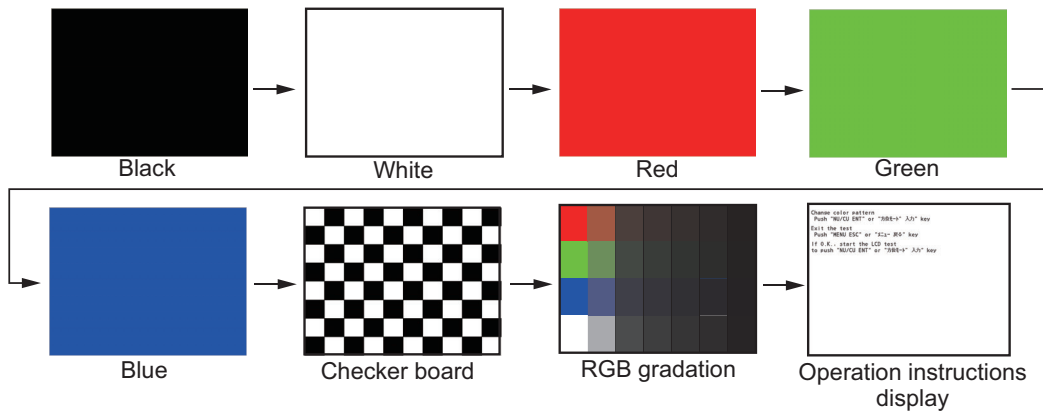

Note: You can cancel the test at any time by pressing the **MENU/ESC** key.

- Press the **MENU/ESC** key to close the test pattern window.

Automatic test

The memory, keyboard and LCD tests are automatically tested.

- Press the **MENU/ESC** key to open the main menu.
- Select [6 Maintenance] then [2 Self Test].
- Select [4 Automatic Test]. The GP-170 automatically repeats the following sequence.

Information screen (refer to section 10.4) → Memory → Keyboard → LCD

Note 1: You can cancel the test at any time by pressing the **MENU/ESC** key.

Note 2: The test stops if the check result for an item other than [Data3] is "NG" or "_ _".

- Press the **MENU/ESC** key to close the automatic test window.

10.6 Audit Log

A list of the stored audit logs can be displayed by a user or administrator (service technician) as follows. The stored audit logs can be exported to a USB flash memory or to an external equipment (see section 10.7 for details).

- Press the **MENU/ESC** key to open the main menu
- Select [6 Maintenance], then select [7 Audit Log].
- Enter the password set in section 9.9, then select [Enter]. The audit log list is shown.

Audit Log			3/12030
Date Time	ID	Description	
31/Oct/2024 12:23:34	0000	Startup successful	
31/Oct/2024 12:23:33	0202	Customer settings changed	
31/Oct/2024 12:23:32	0204	Service settings changed s...	
31/Oct/2024 12:23:31	0006	Self-test detected errors	
31/Oct/2024 12:23:30	0007	Hardware failure occurred	
31/Oct/2024 12:23:29	0206	Successfully imported setti...	
31/Oct/2024 12:23:28	0207	Settings data import failed	
31/Oct/2024 12:23:27	0208	Defaults restored	
31/Oct/2024 12:23:26	0600	Authentication successful	
31/Oct/2024 12:23:25	0104	Successfully Exported	
31/Oct/2024 12:23:24	0105	Settings data Export failed	

4. Select audit log to show the log details window.

Note: With the GNSS position, it may take some time to show the window.

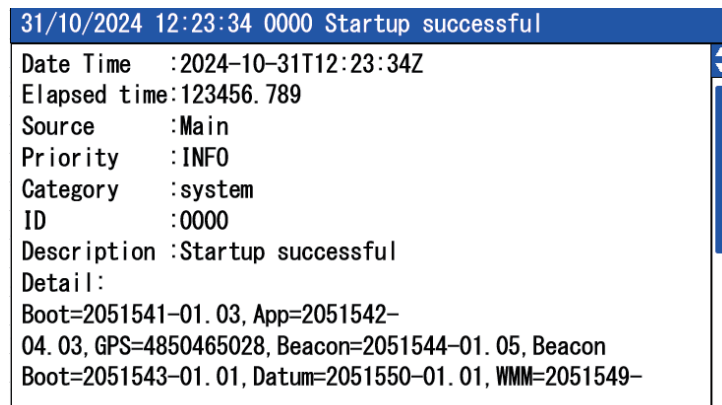

5. Press the **MENU/ESC** key to close the audit log window.

10.7 Backup

The GP-170 can save or load the settings and registered data.

1. Connect a USB flash memory in the USB port.
Note 1: Do not use an encrypted USB flash memory.
Note 2: Keep water away from the unit when the USB flash memory is inserted. The USB port is not waterproof while its cover is removed.
2. Press the **MENU/ESC** key to open the main menu.
3. Select [6 Maintenance] then [3 Backup].

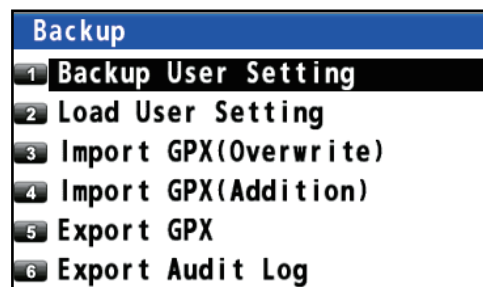

4. Select [1 Backup User Setting], [2 Load User Setting], [3 Import GPX (Overwrite)], [4 Import GPX (Addition)], [5 Export GPX], or [6 Export Audit Log].

[Backup User Setting]: Saves the current settings to a USB flash memory.

[Load User Setting]: Loads the saved settings from a USB flash memory.

[Import GPX (Overwrite)]: Imports the GPX data (marks, waypoints and routes) from a USB flash memory. The GPX data in the GP-170 are deleted.

[Import GPX (Addition)]: Imported data is added to the GPX data in the GP-170. (You can store a maximum of 2,000 marks, 100 routes, and 1,000 waypoints.)

[Export GPX]: Exports the GPX data (marks, waypoints and routes) in the GP-170 to a USB flash memory.

[6 Export Audit Log]: Exports the audit log in the GP-170 to a USB flash memory. Audit log can be also exported via FurunoLink to external equipment. The exported backup data via FurunoLink can be again imported from the external equipment. The user password is required to export audit log.

The confirmation message appears.

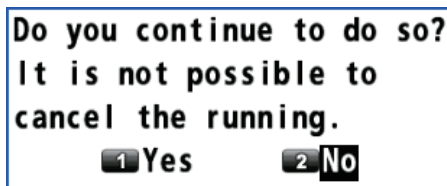

- Select [1 Yes]. The message "Now Processing...." appears.

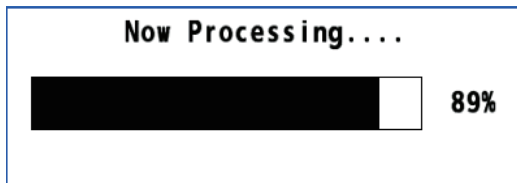

After the process is complete, the GP-170 operates as follows, or do the following according the menu item selected at step 4:

- [Backup User Setting]: The message window automatically closes.
- [Load User Setting], [Import GPX (Overwrite)], [Import GPX (Addition)]: The GP-170 restarts.
- [Export GPX]: After the message window shows 100%, press the **MENU/ESC** key to close the message window.

Note: If a USB flash memory is not set, the following message appears.



Note: Route no. 100 is reserved for the monitored route sent from an ECDIS. A route imported from a USB flash memory may also be assigned this number when that route becomes the 100th route registered in the GP-170. Whenever a monitored route is received, route no. 100 is written over to import the monitored route.

10.8 How to Clear the Memory

You can clear display setting, GPS memory, marks and routes to start afresh.

- Press the **MENU/ESC** key to open the main menu.
- Select [8 System Setting] then [9 Clear Memory].

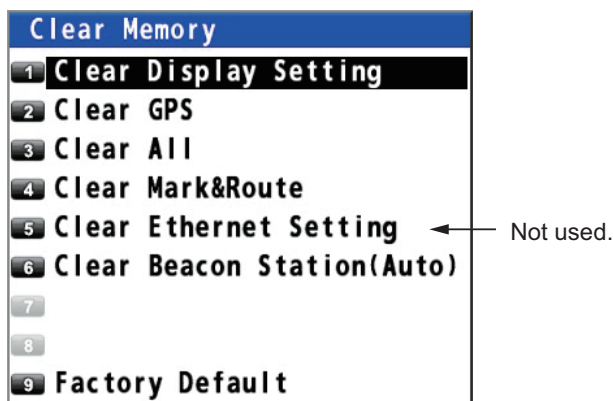

3. Select [1 Clear Display Setting], [2 Clear GPS], [3 Clear All] or [4 Clear Mark&Route].
 - [1 Clear Display Setting]: Clears the display setting.
 - [2 Clear GPS]: Clears the GPS memory.
 - [3 Clear All]*: Clears both display setting and GPS memory.
 - [4 Clear Mark&Route]: Clears marks and routes.
 - [6 Clear Beacon Station (Auto)]*: Clears beacon station (auto) setting.
- *: These menus are for serviceman.
The confirmation message appears.

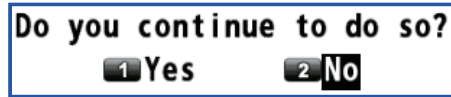

4. Select [1 Yes]. The equipment restarts.

10.9 Checking the Operation of Security Functions

To check that the security functions are working properly, do as follows.

10.9.1 Regular security inspections

Check the network connection

Check that the Ethernet cable is correctly connected to the unit rear. See the Installation Manual (IME-44820) chapter 2 or the Interconnection diagram for the Ethernet cable connection. If there is any unused port, make sure to attach a port blocker to the port.

Check the software version

Check that the software version is latest in the system. The software can be checked and updated in the [Maintenance] - [SW/Database Update] menu. Login to the [Service] menu is required to be able to access to the [SW/Database Update] menu. Contact to your dealer for the latest software.

Check the authentication

Authentication password is required to access to certain menus (for example, access to the audit log). There are two types of login authorities: user (navigator) and administrator (service technician). For the user password, see section 9.9.

Export the log files/check the audit log

Check the IP address and port for the sys log export. To set the IP address/port, select [6 SGW IP ADR/Port] in the [Ethernet] menu. For how to check and export the audit log, see section 10.6.

10.9.2 Security checks during installation

This inspection should be performed by the service technician during the installation of the equipment. The user is not authorized to perform the inspection.

Confirm certification

- Confirm that you cannot log in to the [Service] menu with the wrong password.
- Confirm that you can log in by entering the correct password to log in to the [Service] menu.

Check the network connection

Check that the Ethernet cable is correctly connected to the LAN port at the back of the unit. If there is any unused port, make sure to attach a port blocker to the port to prevent them from being connected to unauthorized cables, etc. Also Check that the network settings are as intended. See the Installation Manual (IME-44820) for the recommended network settings and defaults.

Check the password policy settings

Check that the password settings are as intended on the service menu. See Installation Manual (IME-44820) for details.

10.10 Remedy for Cyber Incidents

10.10.1 Network disturbance

When a network communication overload (risk of a DoS attack) is detected, the “NETWORK OVERLOAD” alert occurs. If an alert occurs, take the following actions.

Actions for the user:

If it is a temporary overload, the alert is automatically cleared. If the alert is not cleared, contact your FURUNO agent or dealer.

Actions for the service technician:

- Disconnect the Ethernet cable to isolate the network(s).
- Check the output data of devices connected to your network configuration, identify the devices that are outputting excessive data, and address them.
- Reconnect to the network.

10.10.2 Password leak

Check the audit log to see if there has been any unauthorized access. If you suspect that the administrator's password may have been leaked, change the password referring to section 9.9.

10.10.3 Data corruption

Actions for the user:

If this equipment becomes inoperable due to a system failure or malware, contact your FURUNO agent or dealer. We recommend that you regularly back up your system to USB flash memory in accordance with section 10.7 to protect against data corruption.

Actions for the service technician:

If necessary, recover data, initialize the system, or reinstall the GP-170 programs. Check that the settings for the security data are compatible with the security policy of the ship's owner. For the menu items related to the security data, see the Installation Manual (IME-44820).

10. MAINTENANCE

This page is intentionally left blank.

APPX. 1 MENU TREE

- ①
 - ├ Trip
 - ├ Status (**Stop**, Start/Restart, Clear)
 - └ Range (Open the setting window.)
 - ├ DC Report
 - ├ DC Report Log (Open the DC report log.)
 - ├ Clear DC Report Log (Yes, **No**)
 - ├ DC Report Setting (Open the setting window.)
 - ├ DC Report Collective setting (**Off**, On)
 - ├ Popup View (**Off**, On)
 - └ Talker (**GQ**, QZ)
 - └ Sound
 - ├ Notice Sound (**Off**, On, Continuous)
 - └ Key Sound (**On**, Off)

5 Alert

- ├ Active Alert (Open the active alert list.)
- ├ Mode*² (**Alert I/F 1**, Alert I/F 2, Legacy) *²: For serviceman.
- ├ Remote Ack I/F*² (**Ack**, BuzzerStop)
- └ Alert Log (Open the alert log.)

6 Maintenance

- ├ Information
 - ├ Main (Open the information for main board.)
 - ├ Panel (Open the information for panel board.)
 - ├ GPS (Open the information for GPS board.)
 - ├ Beacon (Open the information for beacon board.)
 - └ Database (Open the information for database.)
- ├ Self Test
 - ├ Memory Test
 - ├ Keyboard Test
 - ├ LCD Test
 - ├ Automatic Test
 - └ Sound Test*²
- ├ Backup
 - ├ Backup User Setting (Yes, **No**)
 - ├ Load User Setting (Yes, **No**)
 - ├ Import GPX (Overwrite) (Yes, **No**)
 - ├ Import GPX (Addition) (Yes, **No**)
 - ├ Export GPX (Yes, **No**)
 - └ Export Audit Log*³ (Yes, **No**) *³: Password is required.
- ├ SW/Database Update*²
 - ├ Chk the available software
 - ├ Main: Application
 - ├ Main: Boot
 - ├ GPS: Application
 - ├ Beacon: Application
 - └ Beacon: Boot
 - └ Chk the new data table
 - ├ Datum
 - ├ WMM
 - └ DC Report
- ├ Exchange*²
- ├ Service*²
- └ Audit Log*³

7 I/O

- ├ Output Data1 to 4
 - ├ Mode (**IEC/NMEA**, RTCM)
 - ├ Format^{*2} (**IEC 61162-1 Ed.4/5**, IEC 61162-1 Ed.3, NMEA V2.0, NMEA V1.5)
 - ├ Talker^{*2} (**Auto**, GP, GL, GN) *2: For serviceman.
 - ├ BPS^{*2} (**4800 bps**, 9600 bps, 38400 bps) (38400 bps is default for Output Data4.)
 - └ Sentence (AAM: Off, APA: Off, APB: Off, BOD: Off, BWC: Off, BWR: Off, BWW: Off, GBS: Off, GGA^{*3}: Off, GLL: Off, GNS: 1s, GRS: Off, GSA: Off, GST: Off, GSV: Off, RMB: Off, RMC: Off, Rnn: Off, RTE: Off, VDR: Off, VTG: 1s, WCV: Off, WNC: Off, WNR: Off, WPL: Off, XTE: Off, ZDA: 1s, QSM: Off) *3: Only for GPS mode.
- ├ Ethernet
 - ├ Sentence (Options are same as Output Data1 excluding APA, Rnn and WNR.)
 - ├ IP ADR/Port^{*2} (Open the entry window.)
 - ├ MP (Enable, **Disable**)
 - ├ MP IP ADR/Port^{*4} (Open the entry window.) *4: Available when [MP]
 - ├ ND IP ADR/Port (Open the entry window.) is set to [Enable].
 - └ SGW IP ADR/Port (Open the entry window.)
- ├ Data Source Select
 - ├ HDG (**Data1**, Data2, Data4, Ethernet, User Priority)
 - ├ STW (**Data1**, Data2, Data4, Ethernet, User Priority)
 - ├ SST (**Data1**, Data2, Data4, Ethernet, User Priority)
 - └ DPT (**Data1**, Data2, Data4, Ethernet, User Priority)
- ├ Line Monitor
 - ├ Data1 (Open the line monitor for serial data1.)
 - ├ Data2 (Open the line monitor for serial data2.)
 - ├ Data3 (Open the line monitor for serial data3.)
 - ├ Data4 (Open the line monitor for serial data4.)
 - ├ GPS Core^{*2} (**No**, Yes)
 - ├ Beacon^{*2} (**No**, Yes)
 - └ Ethernet Error Counter (Open the Ethernet Error data list.)
- ├ Dual (**No**, Serial (Data2), Ethernet)
- └ Number of digits after decimal point
 - ├ Distance (1, 2, **3**)
 - └ Speed (1, 2, **3**)

8 System Setting

- ├ Language (**English**, 日本語)
- ├ Plotter
 - ├ Bearing Reference (**True**, Magnetic)
 - ├ Magnetic Variation (**Auto**, Manual)
 - ├ Calculation (**RL**, GC)
 - ├ User Defined
 - ├ Custom 1 (SOG, COG, **RNG**, BRG, SST, DPT, XTD, Average COG, Average SOG, TTG, ETA, TRIP, TRIP TIME, Route Distance, Route TTG, ETA (Next), VTD, SET, DRIFT, STW, HDG, Mark/MAX Mark, Track/MAX Track, ETA/ETA (Plan), Magnetic Variarion, LORAN A, LORAN C)
 - ├ Custom 2 (Same as Custom 1; **SOG**)
 - ├ Custom 3 (Same as Custom 1; **HDG**)
 - ├ Custom 4 (Same as Custom 1; **COG**)
 - ├ Custom 5 (Same as Custom 1; **ETA**)
 - ├ Custom 6 (Same as Custom 1; **Route Distance**)
 - ├ Custom 7 (Same as Custom 1; **ETA/ETA (Plan)**)
 - └ Custom 8 (Same as Custom 1; **TTG**)
- └ LORAN (LORAN A, LORAN C)

①

②

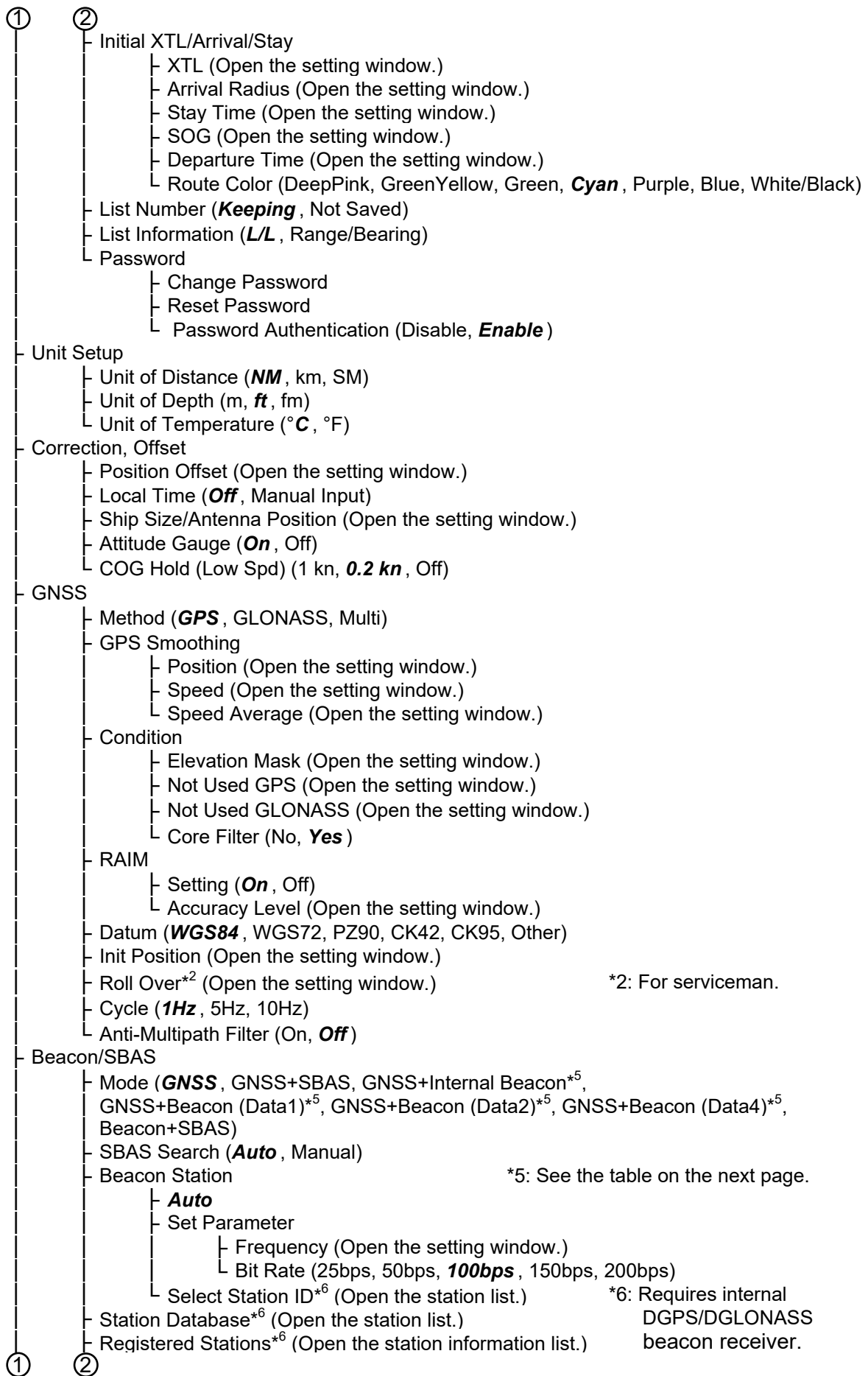

*5

Menu item	w/internal DGPS/DGLONASS beacon receiver	w/o internal DGPS/DGLONASS beacon receiver
GNSS+Internal Beacon	Selectable	Not selectable
GNSS+Beacon (Data1, Data2 or Data4)	Not selectable	Selectable

- ①
 - ②
 - └ Not Used Satellite
 - └ SBAS (Open the setting window.)
 - └ QZSS_L1C/A (Open the setting window.)
 - └ QZSS
 - └ Positioning (Yes, **No**)
 - └ Correction (Yes, **No**)
 - └ Beacon Reset*² *2: For serviceman.
 - └ Network
 - └ SNTP Server (**On**, Off)
 - └ Ethernet*²
 - └ Equipment ID (Open the setting window.)
 - └ SFI*²
 - └ Demo
 - └ Parameter (Open the setting window.)
 - └ Clear Memory
 - └ Clear Display Setting (Yes, **No**)
 - └ Clear GPS (Yes, **No**)
 - └ Clear All*² (Yes, **No**)
 - └ Clear Mark&Route (Yes, **No**)
 - └ Clear Ethernet Setting*⁷ (Yes, **No**) *7: Not used.
 - └ Clear Beacon Station*² (Auto) (Yes, **No**)
 - └ Factory Default*² (Yes, **No**)

APPX. 2 LIST OF TERMS/ICONS/ SYMBOLS

The following table shows the terms, icons, and symbols used in the GP-170.

Terms

Terms	Meaning	Terms	Meaning
ACK	Acknowledge	DTM	Datum
ADR	Automotive Dead Reckoning	E	East
ALARM	Alarm	EGNOS	European Geo-Stationary Navigational Overlay System
ANCH	Anchor Watch	ENT	Enter
ANT	Antenna	EQUIP	Equipment
APR	April	ERR	Error
AUG	August	ETA	Estimated Time of Arrival
AUTO	Automatic	EVENT	Event
AVR	Average	EXT	External
BAM	Bridge Alert Management	FEB	February
BRG	North-referenced bearing	FIX	Fix
BRILL	Brilliance	FREQ	Frequency
CAL	Calibrate	FULL	Full
CCRP	Consistent Common Reference Point	GC	Great Circle
CLR	Clear	GCD	Great Circle Distance
CNCL	Cancel	GLONASS	Global Opening Navigation Satellite System
COG	Course Over the Ground	GND	Ground
CONT	COntrast	GNSS	Global Navigation Satellite System
CPU	Central Processing Unit	GPS	Global Positioning System
CRS	Course	GPX	GPS eXchange Format
CU	Course Up	GRID	Grid
CURS	Cursor	HDG	Heading
DATE	Date	HDOP	Horizontal Dilution Of Precision
DAY	Day	HL	Heading Line
DEC	December	H UP	Head Up
DEL	Delete	ID	Identification
DEP	Departure	IEC	International Electrotechnical Commission
DEST	Destination	IN	In
DGLONASS	Differential GLONASS	IND	Indication
DGNSS	Differential GNSS	INFO	Information
DGPS	Differential GPS	INP	Input
DISP	Display	INT	Interval
DIST	Distance	I/O	Input/Output
DNV	Det Norske Veritas	JAN	January
DPT	Depth	JUL	July

Terms	Meaning	Terms	Meaning
DR	Dead Reckoning, Dead Reckoning Position	JUN	June
DRIFT	Drift	LAT	Latitude
L/L	Latitude and Longitude	Rx, RX	Receive
LOG	Log	S	South
LON	Longitude	SAT	Satellite
LORAN	Long Range Navigation	SBAS	Satellite Base Augmentation System
MAG	Magnetic	SEL	Select
MAN	Manual	SEP	September
MAR	March	SET	Set (i.e., set and drift, or setting a value)
MAY	May	SGW	Service Gateway
MENU	Menu	SIM	Simulation
MIN	Minimum	SLAS	Sub Meter Level Augmentation Service
MOB	Man Overboard	SNR	Signal to Noise Ratio
MSTR	Master	SOG	Speed Over the Ground
N	North	SPD	Speed
NAV	Navigation	SST	Sea Surface Temperature
ND	Network Device	STN	Station
NMEA	National Marine Electronics Association	STW	Speed Through the Water
NOV	November	SV	Space Vehicle
NT	Night	SYM	Symbol(s)
NTP	Network Time Protocol	T	True
NU	North Up	TCPA	Time to CPA
OCT	October	TIME	Ship's Time, Time
OFFSET	Offset	TM	True Motion
ON	On	TOA	Time Of Arrival
OS	Own Ship	TOD	Time Of Departure
OUT	Out/Output	TTG	Time To Go
PDOP	Positional Dilution Of Precision	UTC	Coordinated Universal Time, Universal Time Coordinated
POSN	Position	VAR	Variation
PRN	Pseudo-Random-Noise	VECT	Vector
PWR	Power	VTD	Velocity to Destination
QZSS	Quasi-Zenith Satellite System	W	West
RAIM	Receiver Autonomous Integrity Monitoring	WARNING	Warning
REF	Reference	WAT	Water
RL	Rhumb Line	WER	Word Error Rate
RLD	Rhumb Line Distance	WGS	World Geodetic System
RM	Relative Motion	WPT	Waypoint
RMS	Root Mean Square	XTD	Cross (=X) Track Distance
RNG	Range	XTL	Cross (=X) Track Limit
ROT	Rate Of Turn	XTE	Cross (=X) Track Error
ROUTE	Route		

APPX. 2 LIST OF TERMS/ICONS/ SYMBOLS

Icons

Icons	Meaning	Icons	Meaning
	Active unacknowledged warning		Silenced warning
	Active acknowledged warning		Caution
	Active responsibility transferred warning (For details, see section 8.6.)		Background warning
	Rectified unacknowledged warning		Background caution

Symbols

Symbols	Meaning	Symbols	Meaning
	Marks		Anchor notice
			Arrival notice
			Ship speed notice
	Cursor (Left: Large size, Right: Small size)		Trip notice
	Own ship		XTE notice
	MOB (Man Overboard) mark		High precision speed computing
	North mark		Synchronization with ECDIS
	Chart mode (The cursor is turned off.)		Demo mode
	Cursor mode (The cursor is turned on.)		Correcting by SLAS
	Plotting stopped		DC report received, unread report available (blue)
	Skipped waypoint		Failed to receive DC report, unread report available (blue)
	Reversed route		DC report received, no unread report (gray)
	Attitude gauge		Failed to receive DC report, no unread report (gray)

DC symbols	DC report type	DC symbols	DC report type
	Earthquake early warning, Nankai trough earthquake		Hypocenter
	Seismic intensity		Tsunami, Northwest Pacific tsunami
	Volcano, ash fall		Weather
	Flood		Typhoon
	Marine		

APPX. 3 TIME DIFFERENCES

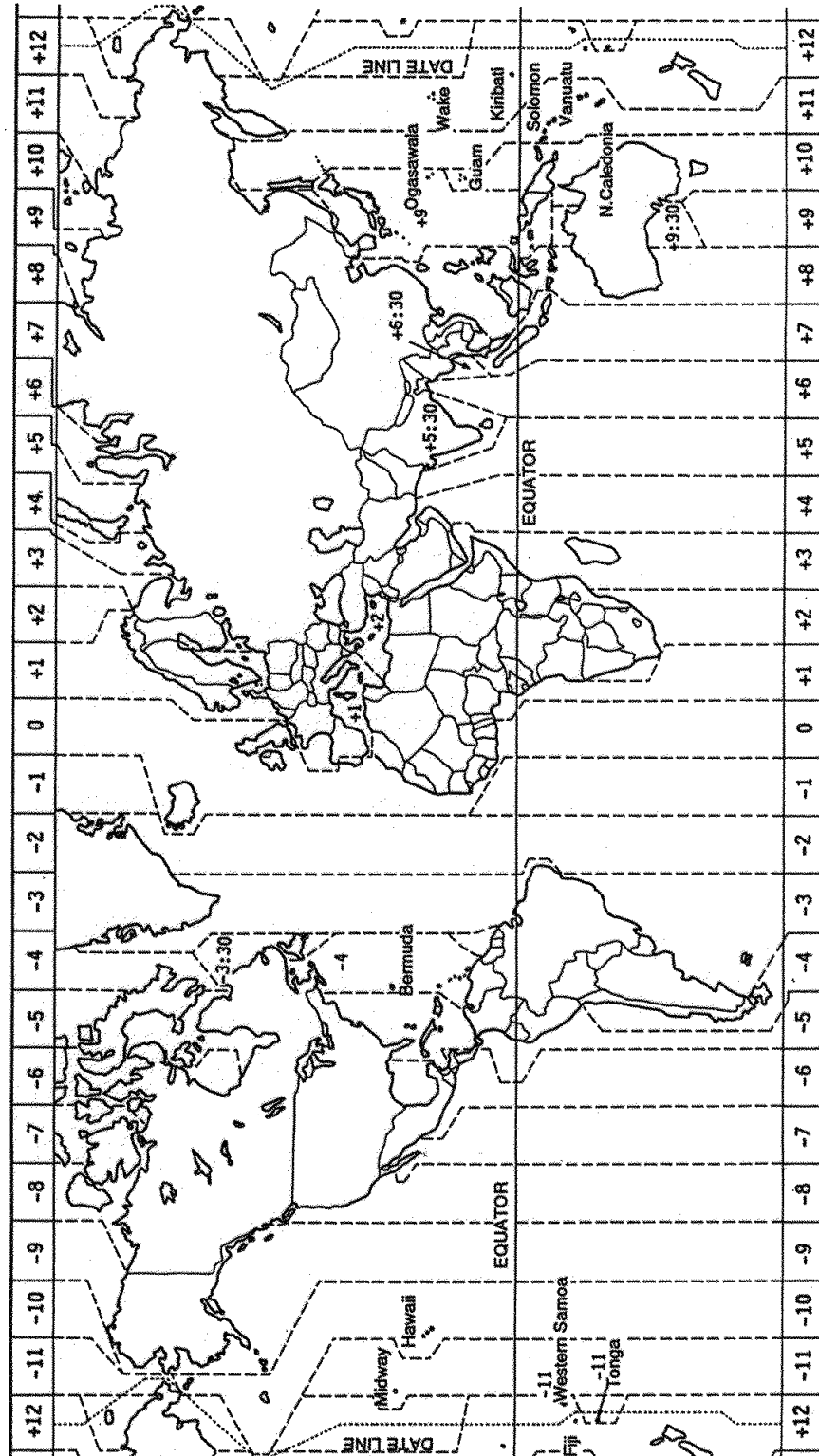

APPX. 4 GEODETIC CHART LIST

001: WGS84		
002: WGS72		
003: TOKYO		
004: NORTH AMERICAN 1927	: Mean Value (Japan, Korea & Okinawa)	
005: EUROPEAN 1950	: Mean Value (CONUS)	
006: AUSTRALIAN GEODETIC 1984	: Mean Value	
007: ADINDAN	: Australia & Tasmania	
008: ADINDAN	: Mean Value (Ethiopia & Sudan)	
009: ADINDAN	: Ethiopia	
010: ADINDAN	: Mali	
011: ADINDAN	: Senegal	
012: AFG	: Sudan	
013: AIN EL ABD 1970	: Somalia	
014: ANNA 1 ASTRO 1965	: Bahrain Is.	
015: ARC 1950	: Cocos Is.	
016: ARC 1950	: Mean Value	
017: ARC 1950	: Botswana	
018: ARC 1950	: Lesotho	
019: ARC 1950	: Malawi	
020: ARC 1950	: Swaziland	
021: ARC 1950	: Zaire	
022: ARC 1950	: Zambia	
023: ARC 1960	: Zimbabwe	
024: ARC 1960	: Mean Value (Kenya & Tanzania)	
025: ARC 1960	: Kenya	
026: ASCENSION IS. 1958	: Tanzania	
027: ASTRO BEACON "E"	: Ascension Is.	
028: ASTRO B4 SOR. ATOLL	: Iwo Jima Is.	
029: ASTRO POS 71/4	: Tern Is.	
030: ASTRONOMIC STATION 1952	: St. Helena Is.	
031: AUSTRALIAN GEODETIC 1966	: Marcus Is.	
032: BELLEVUE (IGN)	: Australia & Tasmania	
033: BERMUDA 1957	: Efate & Erromango Is.	
034: BOGOTA OBSERVATORY	: Bermuda Is.	
035: CAMPO INCHAUSPE	: Columbia	
036: CANTON IS. 1966	: Argentina	
037: CAPE	: Phoenix Is.	
038: CAPE CANAVERAL	: South Africa	
039: CARTHAGE	: Mean Value (Florida & Bahama Is.)	
040: CHATHAM 1971	: Tunisia	
041: CHUA ASTRO	: Chatham Is. (New Zealand)	
042: CORREGO ALEGRE	: Paraguay	
043: DJAKARTA (BATAVIA)	: Brazil	
044: DOS 1968	: Sumatra Is. (Indonesia)	
045: EASTER IS. 1967	: Gizo Is. (New Georgia Is.)	
046: EUROPEAN 1950 (Cont'd)	: Easter Is.	
047: EUROPEAN 1950 (Cont'd)	: Western Europe	
048: EUROPEAN 1950 (Cont'd)	: Cyprus	
049: EUROPEAN 1950 (Cont'd)	: Egypt	
050: EUROPEAN 1950 (Cont'd)	: England, Scotland, Channel & Shetland Is.	
051: EUROPEAN 1950 (Cont'd)	: England, Ireland, Scotland & Shetland Is.	
052: EUROPEAN 1950 (Cont'd)	: Greece	
053: EUROPEAN 1950 (Cont'd)	: Iran	
054: EUROPEAN 1950 (Cont'd)	: Italy, Sardinia	
055: EUROPEAN 1950 (Cont'd)	: Italy, Sicily	
056: EUROPEAN 1950 (Cont'd)	: Norway & Finland	
057: EUROPEAN 1979	: Portugal & Spain	
058: GANDAJIKA BASE	: Mean Value	
059: GEODETIC DATUM 1949	: Republic of Maldives	
060: GUAM 1963	: New Zealand	
061: GUX 1 ASTRO	: Guam Is.	
062: HJORSEY 1955	: Guadalcanal Is.	
063: HONG KONG 1963	: Iceland	
064: INDIAN	: Hong Kong	
065: INDIAN	: Thailand & Vietnam	
066: IRELAND 1965	: Bangladesh, India & Nepal	
067: ISTS 073 ASTRO 1969	: Ireland	
068: JOHNSTON IS. 1961	: Diego Garcia	
069: KANDAWALA	: Johnston Is.	
070: KERGUELEN IS.	: Sri Lanka	
071: KERTAUI 1948	: Kerguelen Is.	
072: LA REUNION	: West Malaysia & Singapore	
073: L. C. 5 ASTRO	: Mascarene Is.	
074: LIBERIA 1964	: Cayman Brac Is.	
075: LUZON	: Liberia	
076: LUZON	: Philippines (excl. Mindanao Is.)	
077: MAHE 1971	: Mindanao Is.	
078: MARCO ASTRO	: Mahe Is.	
079: MASSAWA	: Salvage Islands	
080: MERCHICH	: Eritrea (Ethiopia)	
081: MIDWAY ASTRO 1961	: Morocco	
082: MINNA	: Midway Is.	
083: NAHRWAN	: Nigeria	
084: NAHRWAN	: Masirah Is. (Oman)	
085: NAHRWAN	: United Arab Emirates	
086: NAMIBIA	: Saudi Arabia	
087: MAPARIMA, BWI	: Namibia	
088: NORTH AMERICAN 1927	: Trinidad & Tobago	
089: NORTH AMERICAN 1927	: Western United States	
090: NORTH AMERICAN 1927	: Eastern United States	
	: Alaska	
091: NORTH AMERICAN 1927	: Bahamas (excl. San Salvador Is.)	
092: NORTH AMERICAN 1927	: Bahamas, San Salvador Is.	
093: NORTH AMERICAN 1927 (Cont'd)	: Canada (incl. Newfoundland Is.)	
094: NORTH AMERICAN 1927 (Cont'd)	: Alberta & British Columbia	
095: NORTH AMERICAN 1927 (Cont'd)	: East Canada	
096: NORTH AMERICAN 1927 (Cont'd)	: Manitoba & Ontario	
097: NORTH AMERICAN 1927 (Cont'd)	: Northwest Territories & Saskatchewan	
098: NORTH AMERICAN 1927 (Cont'd)	: Yukon	
099: NORTH AMERICAN 1927 (Cont'd)	: Canal Zone	
100: NORTH AMERICAN 1927 (Cont'd)	: Caribbean	
101: NORTH AMERICAN 1927 (Cont'd)	: Central America	
102: NORTH AMERICAN 1927 (Cont'd)	: Cuba	
103: NORTH AMERICAN 1927 (Cont'd)	: Greenland	
104: NORTH AMERICAN 1927 (Cont'd)	: Mexico	
105: NORTH AMERICAN 1983	: Alaska	
106: NORTH AMERICAN 1983	: Canada	
107: NORTH AMERICAN 1983	: CONUS	
108: NORTH AMERICAN 1983	: Mexico, Central America	
109: OBSERVATORIO 1966	: Corvo & Flores Is. (Azores)	
110: OLD EGYPTIAN 1930	: Egypt	
111: OLD HAWAIIAN	: Mean Value	
112: OLD HAWAIIAN	: Hawaii	
113: OLD HAWAIIAN	: Kauai	
114: OLD HAWAIIAN	: Maui	
115: OLD HAWAIIAN	: Oahu	
116: OMAN	: Oman	
117: ORDNANCE SURVEY OF GREAT BRITAIN 1936	: Mean Value	
118: ORDNANCE SURVEY OF GREAT BRITAIN 1936	: England	
119: ORDNANCE SURVEY OF GREAT BRITAIN 1936	: England, Isle of Man & Wales	
120: ORDNANCE SURVEY OF GREAT BRITAIN 1936	: Scotland & Shetland Is.	
121: ORDNANCE SURVEY OF GREAT BRITAIN 1936	: Wales	
122: PICO DE LAS NIVIES	: Canary Is.	
123: PITCAIRN ASTRO 1967	: Pitcairn Is.	
124: PROVISIONAL SOUTH CHILEAN 1963	: South Chile (near 53°S)	
125: PROVISIONAL SOUTH AMERICAN 1956	: Mean Value	
126: PROVISIONAL SOUTH AMERICAN 1956	: Bolivia	
127: PROVISIONAL SOUTH AMERICAN 1956	: Chile-Northern Chile (near 19°S)	
128: PROVISIONAL SOUTH AMERICAN 1956	: Chile-Southern Chile (near 43°S)	
129: PROVISIONAL SOUTH AMERICAN 1956	: Columbia	
130: PROVISIONAL SOUTH AMERICAN 1956	: Ecuador	
131: PROVISIONAL SOUTH AMERICAN 1956	: Guyana	
132: PROVISIONAL SOUTH AMERICAN 1956	: Peru	
133: PROVISIONAL SOUTH AMERICAN 1956	: Venezuela	
134: PUERTO RICO	: Puerto Rico & Virgin Is.	
135: QATAR NATIONAL	: Qatar	
136: QORNOQ	: South Greenland	
137: ROME 1940	: Sardinia Is.	
138: SANTA BRAZ	: Sao Miguel, Santa Maria Is. (Azores)	
139: SANTO (DOS)	: Espirito Santo Is.	
140: SAPPER HILL 1943	: East Falkland Is.	
141: SOUTH AMERICAN 1969	: Mean Value	
142: SOUTH AMERICAN 1969	: Argentina	
143: SOUTH AMERICAN 1969	: Bolivia	
144: SOUTH AMERICAN 1969	: Brazil	
145: SOUTH AMERICAN 1969	: Chile	
146: SOUTH AMERICAN 1969	: Columbia	
147: SOUTH AMERICAN 1969	: Ecuador	
148: SOUTH AMERICAN 1969	: Guyana	
149: SOUTH AMERICAN 1969	: Paraguay	
150: SOUTH AMERICAN 1969	: Peru	
151: SOUTH AMERICAN 1969	: Trinidad & Tobago	
152: SOUTH AMERICAN 1969	: Venezuela	
153: SOUTH ASIA	: Singapore	
154: SOUTHEAST BASE	: Porto Santo & Madeira Is.	
155: SOUTHWEST BASE	: Faial, Graciosa, Pico, Sao Jorge & Terceira Is.	
156: TIMBALAI 1948	: Brunei & East Malaysia (Sarawak & Sabah)	
157: TOKYO	: Japan	
158: TOKYO	: Korea	
159: TOKYO	: Okinawa	
160: TRISTAN ASTRO 1968	: Tristan da Cunha	
161: VITI LEVU 1916	: Viti Levu Is. (Fiji Is.)	
162: WAKE-ENIWETOK 1960	: Marshall Is.	
163: ZANDERIJ	: Surinam	
164: BUKIT RIMPAH	: Bangka & Belitung Is. (Indonesia)	
165: CAMP AREA ASTRO	: Camp Marmurdo Area, Antarctica	
166: G. SEGARA	: Kalimantan Is. (Indonesia)	
167: HERAT NORTH	: Afghanistan	
168: HU-TZU-SHAN	: Taiwan	
169: TANANARIVE OBSERVATORY 1925	: Madagascar	
170: YACARE	: Uruguay	
171: RT-90	: Sweden	
172: CK42 (PULKOVO 1942)	: Russia	
173: FINNISH KKK	: Finland	
174: PZ90	: Russia	
175: CK95	: Russia	

APPX. 5 WHAT IS SBAS/ QZSS (SLAS)/DC Report?

SBAS

A satellite based augmentation system, or SBAS (Satellite Based Augmentation System), is an augmentation system that uses additional messages from satellite broadcasts to support regional and wide area augmentation. SBAS provides GPS signal corrections to SBAS users, for even better position accuracy, through the GPS error corrections that are widely broadcasted from the geostationary satellite.

SBAS is used in America, Europe, Japan and India. These four systems; WAAS, EGNOS, MSAS and GAGAN, have interoperability. The illustration below shows the coverage area for each provider. This manual uses "SBAS" for these four providers generically.

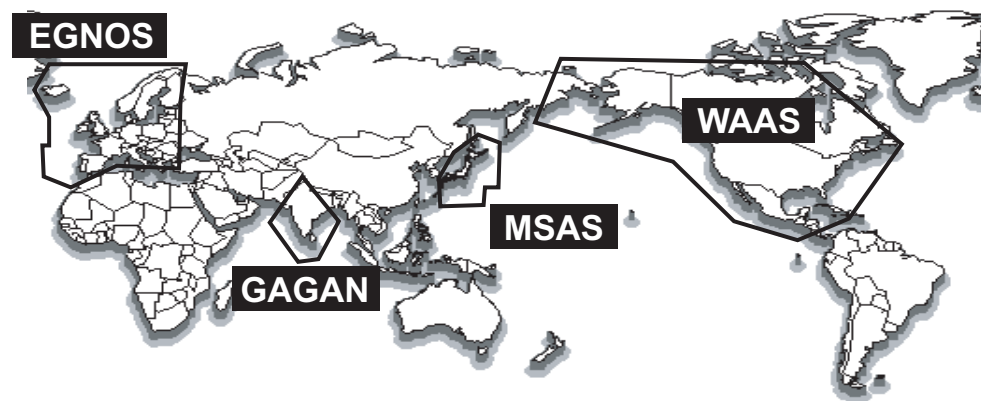

Provider	Satellite type	Longitude	Satellite No.
WAAS (Wide Area Augmentation System, America)	Intelsat Galaxy XV	133°W	135
	TeleSat Anik F1R	107.3°W	138
	Inmarsat-4-F3	98°W	133
EGNOS (Euro Geostationary Navigation Overlay Service, Europe)	Inmarsat-3-F2/AOR-E	15.5°W	120
	Artemis	21.5°E	124
	Inmarsat-4-F2	25°E	126
	SES-5	5°E	136
MSAS (Multi-Functional Satellite Augmentation System, Japan)	MTSAT-1R	140°E	129
	MTSAT-2	145°E	137
GAGAN (GPS And GEO Augmented Navigation, India)	GSAT-8	55°E	127
	GSAT-10	83°E	128

As of March 6th, 2014

QZSS (SLAS)

QZSS (SLAS) (Quasi-Zenith Satellite System) is the Japanese satellite positioning system composed mainly of satellites of quasi-zenith orbit. Since QZSS can be used together with GPS, QZSS secures the number of satellites that can perform stable high-accuracy positioning.

Note: Positioning correction cannot be guaranteed outside of the coverage area.

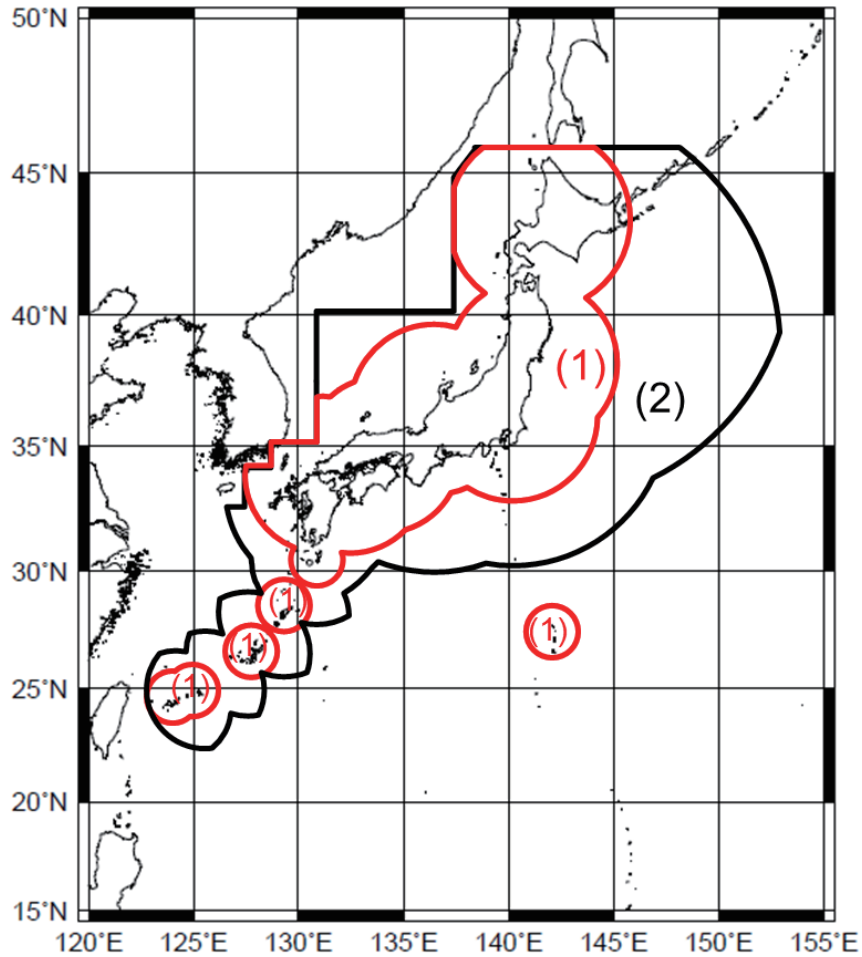

Source: Cabinet Office, Government of Japan, “PS-QZSS-001”, November 5, 2018, Figure 5.2-1 on page 16

The table below shows the positioning accuracy when using SLAS correction.

Positioning accuracy

Area	Positioning error (Horizontal)
Areas (1) and (2)	3.0 m approx. (2 drms)

The table below shows the available QZSS (SLAS) satellites.

QZSS (SLAS)

Satellite name	Longitude	Satellite no.	PRN for positioning	PRN for correction
QZS-1	-	J001	193	183
QZS-2	-	J002	194	184
QZS-3	127°E	J003	199	189
QZS-4	-	J004	195	185

As of February 25th, 2019

The QZSS ground track is a figure eight track shown in the figure below. Satellites remain in the northern hemisphere for about 13 hours, and about 11 hours in the southern hemisphere.

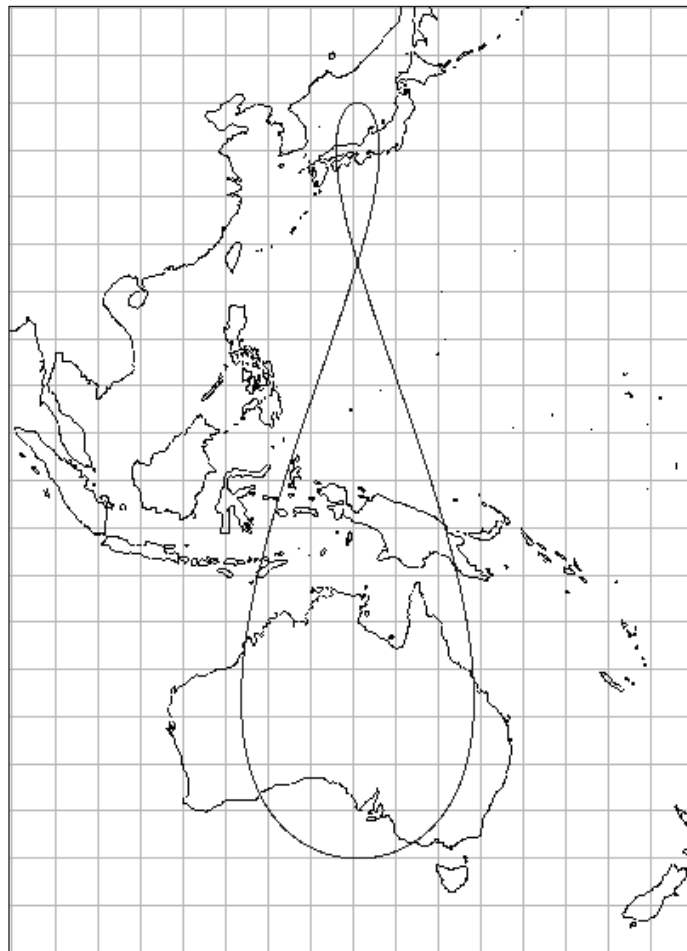

QZSS ground track (except for QZS-3)

Source: Cabinet Office, Government of Japan, "PS-QZSS-001", November 5, 2018, Figure 3.1-2 on page 9

DC report

The DC report (Satellite Report for Disaster and Crisis Management) is a service that sends disaster information, such as when an earthquake or tsunami is announced by a disaster prevention agency, via QZSS. This service uses the L1S signal as well as the sub-meter class positioning reinforcement service, and transmits disaster information, etc. every four seconds. As shown in the figure below, the service range is inside the border line that includes Japan and Russia and Oceania.

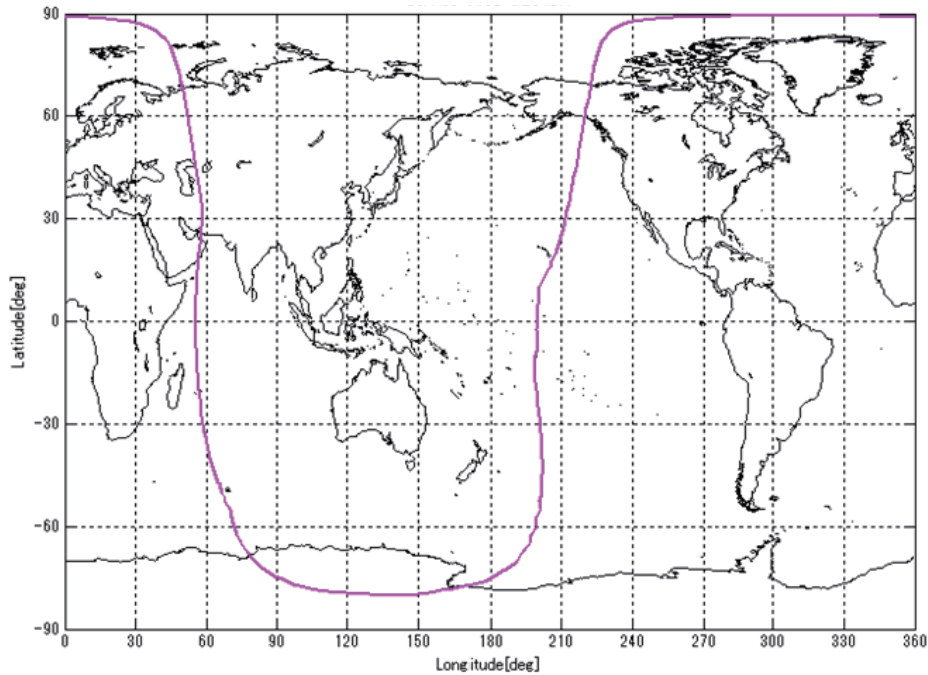

Coverage area of the DC report

Source: Cabinet Office, Government of Japan, “PS-QZSS-001”, November 5, 2018, Figure 7.2-1 on page 24

APPX. 6 PARTS LIST/LOCATION

Parts list

This equipment contains complex modules in which fault diagnosis and repair down to component level are not practical (IMO A.694(17)/8.3.1). Only some discrete components are used. FURUNO Electric Co., Ltd. Believes identifying these components is of no value for shipboard maintenance; therefore, they are not listed in this manual. Major modules can be located on the parts location photos below.

ELECTRICAL PARTS LIST	Unit	Display Unit GP-170
PRINTED CIRCUIT BOARD		
GR-1700(20P8208), BEACON		
20P8209, MAIN		
20P8210, PNL		
20P8211, GPS		
20P8220, UFL-ANT		
LCD		
NL6448BC18-01F/COM57H5N32XSC*		

*: This equipment is equipped with either LCD NL6448BC-01F or LCD COM57H5N32XSC.

Parts location

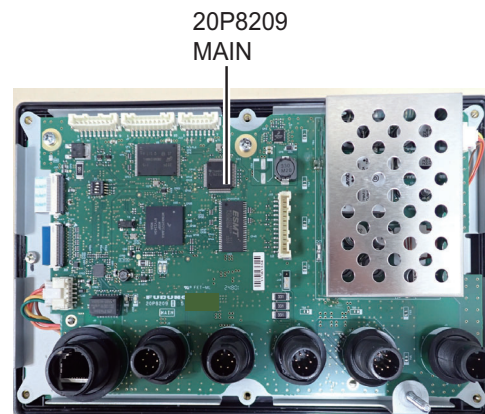
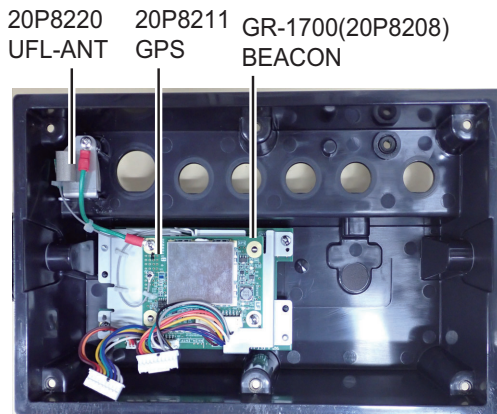

Display unit, cover opened

*: The figure shows LCD COM57H5N32XSC.

APPX. 7 ALERT LIST

The table below shows the alert no., alert title (only for Alert I/F 2), alert text, priority, meaning and remedy for each alert.

Note: The BAM function type for the GP-170 is "P".

Alert I/F 2

All warnings have responsibility transfer function.

Note: "Inst." denotes "Instance number" for the alert.

No.	Inst.	Alert title	Alert description text	Priority	Meaning	Remedy
3056	0	HDOP exceeded	HDOP exceeded.	Caution/B	The value of HDOP (Horizontal Dilution of Precision) is 4 or above. HDOP threshold being permanently set to 4.	If the same state continues for five minutes, contact your dealer.
3008	1	Loss of position	GNSS core fault.	Warning/B	The signal from GNSS core is not received for three seconds.	Restart the GP-170. If the alert occurs again, contact your dealer.
	2		Too few tracking Satellites.		No positioning data.	If the same state continues for five minutes, contact your dealer.
	3		Antenna short-circuited.		The antenna has shorted out.	If this condition frequently occurs, contact your dealer.
	4		First fix fault (for Russian mode)		No positioning data for five minutes after startup.	If the same state continues over five minutes, contact your dealer.
3055	0	Lost DIF Signal	Loss of differential signal.	<ul style="list-style-type: none"> Russian mode: Warning/B Others: Caution/B 	More than 10 seconds have passed since the last beacon message is received.	<u>DGPS/DGLON-ASS fix use</u> If this condition frequently occurs in the service area of the Beacon stations, contact your dealer.
3012	0	Doubt DIF Signal	Beacon status unhealthy.		The beacon station selected automatically is unhealthy.	Change the Beacon station to another available.
			For Russian mode: Doubtful DIF Sig			

No.	Inst.	Alert title	Alert description text	Priority	Meaning	Remedy
401903	0	Audit log fail	Check the audit log	Caution/B	Audit log error.	Restart the GP-170 and contact your dealer for advice.
401906	0	Network overload	Check other devices in the network	Caution/B	Network overload detected.	Check network status and devices in network.

Alert I/F 1, Legacy

No.	Alert description text	Priority	Meaning	Remedy
009	Antenna short-circuited.	Warning/B	The antenna has shorted out.	If this condition frequently occurs, contact your dealer.
010	<ul style="list-style-type: none"> • D3D turned to 3D. • D3D turned to 2D. • D2D turned to 3D. • D2D turned to 2D. • S3D turned to 3D. • S3D turned to 2D. • S2D turned to 3D. • S2D turned to 2D. • Q3D turned to 3D. • Q3D turned to 2D. • Q2D turned to 3D. • Q2D turned to 2D. • D3D turned to "No Fix". • D2D turned to "No Fix". • S3D turned to "No Fix". • S2D turned to "No Fix". • Q3D turned to "No Fix". • Q2D turned to "No Fix". 	Caution/B	The positioning system turns from DGPS/DGLONASS to GPS/GLONASS.	<ul style="list-style-type: none"> • <u>DGPS/DGLONASS fix use</u> If this condition frequently occurs in the service area of the Beacon stations, contact your dealer. • <u>SBAS fix use</u> If this condition frequently occurs in the service area of the SBAS satellites, contact your dealer. • <u>QZSS fix use</u> If this condition frequently occurs in the service area of the QZSS satellites, contact your dealer.
210	HDOP exceeded.	Caution/B	The value of HDOP (Horizontal Dilution of Precision) is 4 or above. HDOP threshold being permanently set to 4.	If the same state continues for five minutes, contact your dealer.
211	No calculation of position.	Warning/B	The signal from GNSS core is not received for three seconds.	Restart the GP-170. If the alert occurs again, contact your dealer.
212	Loss of position.	Warning/B	No positioning data.	If the same state continues for five minutes, contact your dealer.
213	Loss of differential signal.	Caution/B	More than 10 seconds have passed since the last beacon message is received.	<u>DGPS/DGLONASS fix use</u> If this condition frequently occurs in the service area of the Beacon stations, contact your dealer.
215	Beacon status unhealthy.	Caution/B	The beacon station selected automatically is unhealthy.	Change the Beacon station to another available.

**SPECIFICATIONS OF GNSS NAVIGATOR
GP-170**

1 GNSS RECEIVER

- 1.1 Receiving frequency 1575.42 MHz (GPS, QZSS, SBAS), 1602.5625 MHz (GLONASS)
- 1.2 Tracking code GPS/SBAS/QZSS: L1 C/A, SBAS: L1Sb, QZSS: L1S, GLONASS: L1OF
- 1.3 Number of channel GPS: 12 channels parallel, 12 satellites
QZSS: 4 channels parallel, 4 satellites
SBAS: 2 channels parallel, 2 satellites
GLONASS: 10 channels parallel, 10 satellites
- 1.4 Accuracy (dependent on ionospheric activity and multipath)
GPS 10 m approx. (2drms, HDOP<4)
DGPS 5 m approx. (2drms, HDOP<4)
WAAS 3 m approx. (2drms, HDOP<4)
MSAS 7 m approx. (2drms, HDOP<4)
QZSS (SLAS) 3 m approx. (2drms, HDOP<4)
- 1.5 Ship's speed accuracy 0.2 kn (10kn or less), 2 % of ship's speed (more than 10kn), excluding influence of roll and pitch
- 1.6 Course accuracy Smoothing time constant = 5 s (default)

Speed range [kn]	Accuracy of COG [°] *
0 to ≤1	Unreliable or not available
1 to ≤2	±3.4°
2 to ≤4	±2°
4 or more	±1°

*: Ship maneuvers may add inaccuracy

- 1.7 Position fixing time Cold start: 90 s typical
- 1.8 Tracking velocity 1000 kn
- 1.9 Position update Interval*
GPS/Combine 1 s (standard), 0.1 s (minimum)
GLONASS 1 s**

*: Set the position update interval 0.1 s or 0.2 s for high-speed craft. Set the positioning cycle 5 or 10 Hz according to the position update interval; 5/10 Hz for 0.2s interval, 10 Hz for 0.1s interval.

**: Only 1 s in GLONASS mode.

2 DISPLAY SECTION

- 2.1 Screen
NL6448BC18-01F 5.7-inch color LCD, 116.16 x 87.12 mm, 640 x 480 (VGA)
COM57H5N32XSC 5.7-inch color LCD, 115.20 x 86.40 mm, 640 x 480 (VGA)
- 2.2 Brilliance 700 cd/m² typical
- 2.3 Visible distance 0.625 m nominal
- 2.4 Display modes Plotter, Highway, Course, Data, Integrity
- 2.5 Projection Mercator

- 2.6 Track plotter display
 - Scale 0.125 to 1024 NM, 14 steps
 - Latitude limits Between 88° N and 88° S
 - Plot interval By time 0 to 60m00s or by distance 0 to 99.99 NM, sm/km or halt
- 2.7 Memory capacity
 - Track and marks Track: 1,000 points, Mark: 2,000 points
 - Waypoints 1,000 points with 20 characters comment each
 - Route 100 routes (containing 1,000 waypoints each)
No. 001 to 099: for registering routes
No. 100: for reading from USB flush memory/ synchronizing with ECDIS
- 2.8 Notice Arrival and anchor watch, Cross track error, Speed, Trip, DC report
- 2.9 Alerts Differential positioning interruption, HDOP overshoot, Own ship positioning fail, Own ship position lost, Beacon signal lost, Beacon malfunction, Antenna short-circuit
- 2.10 Satellite information Satellite number, Bearing, Elevation, Signal level, DOP, Status

3 DGPS/DGLONASS BEACON RECEIVER (for DGPS/DGLONASS model)

- 3.1 Frequency range 283.5 kHz to 325.0 kHz
- 3.2 Channel separation 500 Hz
- 3.3 MSK rate 25, 50, 100, 150, 200 bps
- 3.4 Operation mode Auto or manual

4 INTERFACE

- 4.1 Number of ports Serial: 4 ports (IEC61162-1 I/O: 2, O: 1, IEC61162-2 I/O: 1), Ethernet (IEC61162-450):1 port, USB: 1 port
- 4.2 Data format IEC61162-1 Ed.3/4/5, NMEA0183 Ver1.5/2.0/4.0, IEC61162-450 Ed.2.0 2018-05
- 4.3 Data port 1, 2 and 4
IEC/NMEA Mode
IN: ACK, ACN, CRQ, DBT, DPT, HBT, HDG, HDM*², HDT*², MSK, MSS, MTW, THS, TLL, VBW, VHW
OUT: AAM, ALC, ALF, ALR, APA*², APB, ARC, BOD, BWC, BWR, BWW, DTM, GBS, GGA*³, GLL, GNS, GRS, GSA, GST, GSV, HBT, MSK*, MSS*, POS, QSM, RMB, RMC, Rnn*², RTE, VDR, VTG, WCV, WNC, WNR, WPL, XTE, ZDA
RTCM Mode
IN/ OUT: MSK, MSS
DGPS/DGLONASS correction data in RTCM SC-104 V2.3
- 4.4 Data port 3
IN: MOB from external device (contact closure)
OUT: AAM, ALC, ALF, ALR, APA*², APB, ARC, BOD, BWC, BWR, BWW, DTM, GBS, GGA*³, GLL, GNS, GRS, GSA, GST, GSV, HBT, MSK*, MSS*, POS, QSM, RMB, RMC, Rnn*², RTE, VDR, VTG,

- WCV, WNC, WNR, WPL, XTE, ZDA
 - RTCM Mode Output
 - MSK, MSS
 - DGPS/DGLONASS correction data in RTCM SC-104 V2.3
 - 4.5 Proprietary sentences (output only)
 - PFEC
 - GPals, GPasc, GPdst, GPmr2, GPmsk, GPrai, GPreq, GPrt2, GPtrp, Ilalr, pidat, rminf
 - 4.6 Ethernet
 - 100Base-TX, RJ45 connector (waterproof), IGMPv2 acceptable
 - IEC61162-450 transmission group (datagram type: UdpbC only)
 - IN:
 - MISC, SATD, NAVD
 - OUT:
 - Arbitrary (default: NAVD)
 - Network function (except IEC61162-450)
 - SNTP, HTTP, Furuno Management Protocol (FMP)
 - Sentences
 - IN:
 - ACK, ACN, DBT, DPT, HBT, HDG, HDM*2, HDT*2, MTW, THS, TLL, VBW, VHW
 - OUT:
 - AAM, ALC, ALF, ALR, APB, ARC, BOD, BWC, BWR, BWW, DTM, GBS, GGA*3, GLL, GNS, GRS, GSA, GST, GSV, HBT, POS, QSM, RMB, RMC, RTE, SRP, VDR, VTG, WCV, WNC, WPL, XTE, ZDA
- *: MSK: Internal/external beacon receiver required, MSS: internal beacon receiver required.
 *2: not used for SOLAS ships.
 *3: GPS mode only.

5 POWER SUPPLY

- 5.1 Display unit
 - 12-24 VDC: 0.8-0.4 A (w/ internal beacon receiver)
- 5.2 Rectifier (option)
 - PR-62
 - 100/110-115/220/230 VAC, 1 phase, 50/60Hz
- 5.3 AC/DC power supply unit (option)
 - PR-240
 - 100-115/220-230 VAC, 1 phase, 50/60Hz
 - PR-241
 - 100-230 VAC, 1 phase, 50-60 Hz

6 ENVIRONMENTAL CONDITIONS

- 6.1 Ambient temperature
 - Antenna unit
 - 25°C to +70°C
 - Display unit
 - 15°C to +55°C
- 6.2 Relative humidity
 - 95% or less at +40°C
- 6.3 Degree of protection
 - Antenna unit
 - IP56
 - Display unit
 - IP25 (USCG CFR-46), IPX0 (USB port cover opened)
- 6.4 Vibration
 - IEC 60945 Ed.4

7 UNIT COLOR

- 7.1 Antenna unit
 - N9.5
- 7.2 Display unit
 - N2.5

INDEX

- A**
- Alert listAP-16
- Alerts
 - acknowledging 8-6
 - list 8-5
 - log 8-5
 - overview 8-1
 - silencing 8-6
- Antenna position 9-3
- Anti-multipath mode 9-9
- Attitude gauge 9-3
- B**
- Background color 2-1
- Backup 10-7
- Beacon 9-11
- Bearing reference 2-6
- Brilliance 1-4
- C**
- Centering 2-3
- Clearing memory 10-8
- COG vector 2-4
- Context menu overview 1-10
- Control description 1-1
- Core filter 9-6
- Course display 7-5
- Cursor on/off 2-2
- Cursor size 2-2
- D**
- Data display 7-6
- Datum 9-7
- DC Report 6-5
- Demo mode 9-25
- Destination
 - cancelling 5-3
 - setting 5-1
- Disable satellite 9-6
- Display mode 1-5
- Display orientation 2-1
- Drift 5-6
- Dual configuration 9-21
- E**
- ECDIS sync configuration 9-22
- Equipment information 10-3
- ETA 5-5
- Ethernet setting 9-16
- Event marks
 - editing 3-7
 - presetting 3-5
 - putting 3-5
- G**
- Geodetic chart listAP-10
- GPS smoothing 9-5
- Grid 2-3
- H**
- Heading line on/off 2-4
- Highway display 7-4
- I**
- Input data selection 9-18
- K**
- Key sound 1-2
- L**
- Language selection 9-14
- Life of LCD 10-1
- Line monitor log 9-19
- List overview 1-9
- M**
- Magnetic variation 2-6
- Main menu overview 1-8
- Maintenance 10-1
- Marks
 - editing 3-7
 - erasing 3-8
 - presetting 3-1
 - putting 3-2
- Menu treeAP-1
- MOB mark
 - putting 3-6
- N**
- Notice
 - anchor 6-2
 - arrival 6-2
 - DC report 6-5
 - ship speed 6-3
 - sound 6-1
 - trip 6-4
 - XTE 6-3
- O**
- Output setting 9-15
- P**
- Parts listAP-15
- Parts locationAP-15
- Password 9-23
- Position offset 9-1
- Positioning cycle 9-8
- Power on/off 1-3
- R**
- RAIM 9-7
- Routes
 - changing direction 4-11
 - copying 4-11
 - creating 4-3, 4-4
 - editing 4-6

INDEX

erasing	4-12
presetting	4-1
S	
Sat view display	7-1
Satellite elevation	9-5
SBAS	9-11, AP-11
Self test	10-4
Ship size	9-3
Station data	9-12
Symbols	AP-8
System configurations	ix
T	
Terms	AP-6
Time difference	9-2, AP-9
Time mark	2-5
Tracks	
color	2-8
erasing	2-8
plotting and recording	2-7
plotting interval	2-7
Trip distance	5-6
Troubleshooting	10-2
TTG	5-4, 5-5
U	
Unit	9-1
W	
Waypoint	
deleting	4-9
editing	4-7
inserting	4-10
temporarily deselecting	4-8
X	
XTL line on/off	2-3
Z	
Zoom function	2-1

Publication No. DOCQA1985

Declaration of Conformity



0575



0097

We **FURUNO ELECTRIC CO., LTD.**

(Manufacturer)

9-52 Ashihara-Cho, Nishinomiya City, 662-8580, Hyogo, Japan

(Address)

declare under our sole responsibility that the product

GNSS NAVIGATOR GP-170

(Serial No. 6445/6452/6453/6458/6459/6460/6464-xxxx)

(Model name, type number)

to which this declaration relates conforms to the following standard(s) or other normative document(s)

EU

Directive 2014/90/EU on Marine Equipment (MED) as amended by the Implementing Regulation (EU) 2025/1533

SOLAS 74 Reg. V/18, V/19 & X/3
 IMO Res. A.694(17), MSC.36(63), MSC.97(73),
 MSC.112(73), MSC.113(73), MSC.114(73),
 MSC.115(73), MSC.191(79), MSC.302(87)

(title and number of the requirements)

For assessment, see

- EC-type examination certificate (Module B) MEDB000039D Rev.8: DNV AS (0575)
- Product Quality System certificate (Module D) MEDD00002CD Rev.9: DNV AS (0575)

On behalf of Furuno Electric Co., Ltd.

Nishinomiya City, Japan
 23 September 2025

Akihiko Kanechika
 Department General Manager
 Quality Assurance Department

(Place and date of issue)

(name and signature or equivalent marking of authorized person)

Publication No. SOCQA0086

PSTI Statement of Compliance

We

FURUNO ELECTRIC CO., LTD.

(Name of manufacturer of the product)

9-52 Ashihara-Cho, Nishinomiya City, 662-8580, Hyogo, Japan

(Address of manufacturer of the product)

declare under our sole responsibility that the product

GNSS NAVIGATOR,

GP-170

(Product type, batch)

December / 31 / 2029

(Support period for the product)

https://www.furuno.co.jp/en/csr/sociality/customer/product_security.html

(Weblink for latest information and contact to report to the manufacturer security issues)

to which this declaration relates conforms to the following standard(s) or other normative document(s)

Product Security and Telecommunications Infrastructure Act 2022
 Product Security and Telecommunications Infrastructure (Security Requirements for Relevant Connectable Products) Regulations 2023 Schedule 1

On behalf of Furuno Electric Co., Ltd.

Nishinomiya City, Japan
 19 November 2025

(Place and date of issue)

Akihiko Kanechika
 Department General Manager
 Quality Assurance Department

(Signature, name and function of the signatory)